



Vol 6

Solid & Coolant-Through Carbide Drills

HY-PRO[®] CARB Drills

3D • 5D • 8D



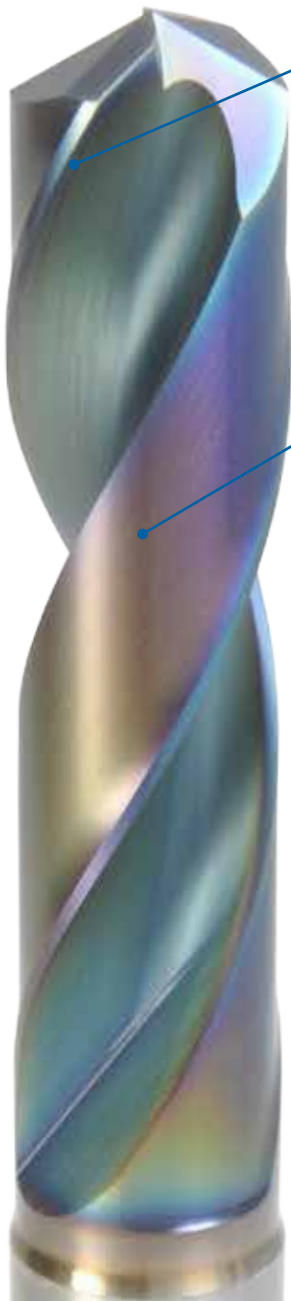

Negative Radial Rake

for stronger cutting edge that resists chipping.

Coolant-Through

reduces heat, improves chip evacuation and enables faster drilling speeds.

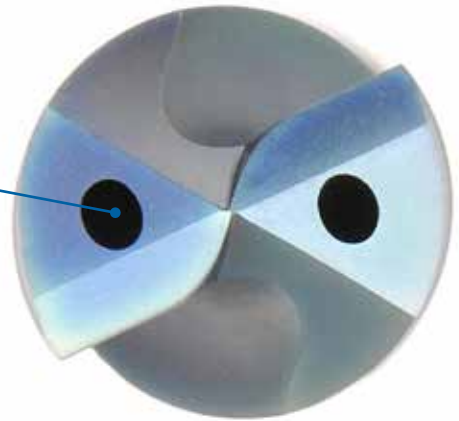

WD1 Coating

for high oxidation temperatures and increased wear resistance.

Large Negative Radial Rake Angle

Negative Rake Angle for a Stronger Cutting Edge

Large Negative Radial Rake

Stronger Cutting Edge

Small Honing Amount

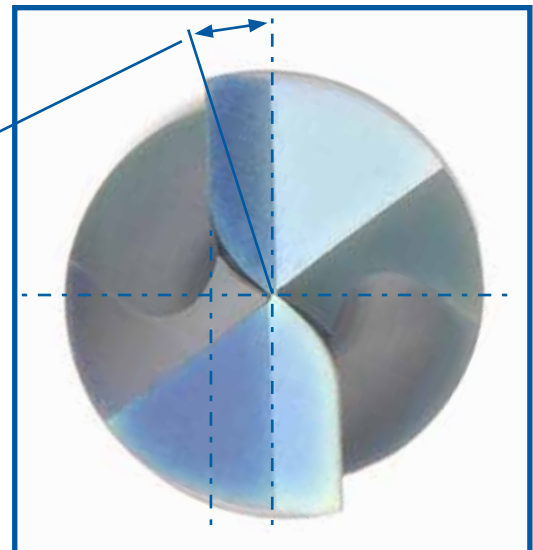

Efficient Chip Evacuation

Produces Small Chips and Provides Wide Chip Room



Stability and Improved Tool Life

Durability in Low Carbon Steel (40 HRC)

The HY-PRO® CARB drill provides more stability and greater tool life in low carbon steel, successfully machining a total of 269 linear inches. The HY-PRO® CARB drill processed more than twice the number of holes as the competitor which failed after 142 holes.

Tool	HY-PRO® CARB 3D	Competitor
Drill Size	Ø10mm	
Work Material	Low Carbon Steel (40 HRC)	
Cutting Speed	197 SFM (1911 RPM)	
Feed Rate	9 IPM (0.0047 IPR)	
Depth of Hole	21 mm (Through)	
Coolant	Water-Soluble	
Machine	Horizontal Machining Center	

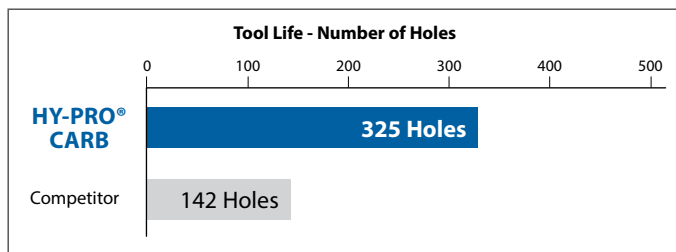

Longer Tool Life

Greater Tool Life in Alloy Steel (15 HRC)

The HY-PRO® CARB drill's WD1 coating provides increased wear resistance, enabling it to machine **1,200 more holes** than the competition before showing wear.

Tool	HY-PRO® CARB 5D	Competitor
Drill Size	Ø4.6mm	
Work Material	Alloy Steel (15 HRC)	
Cutting Speed	190 SFM (4007 RPM)	
Feed Rate	19.6 IPM (0.0049 IPR)	
Depth of Hole	15 mm (Blind)	
Coolant	Air	
Machine	Horizontal Machining Center	

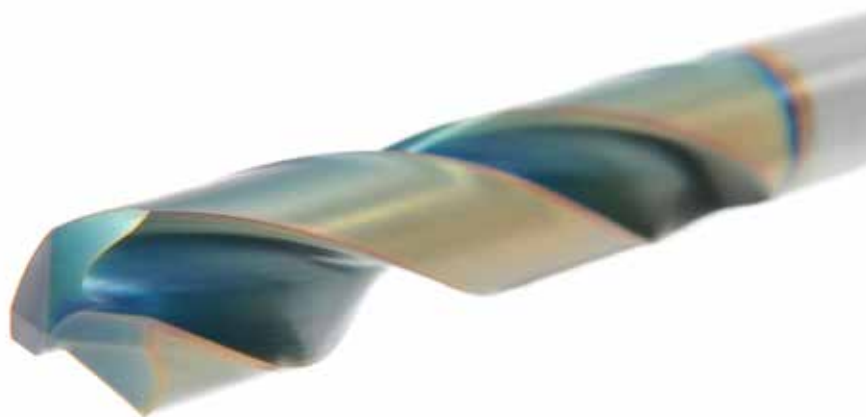
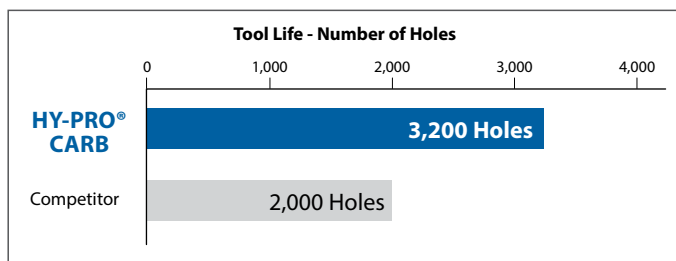

Coolant-Through Performance

Better Chip Evacuation and Longer Tool Life in Ductile Cast Iron (25 HRC)

With coolant-through, the HY-PRO® CARB drills are capable of greater drilling speeds and longer tool life. The HY-PRO® CARB drill machined over 10,000 holes (12,500 linear inches) in ductile cast iron while the competitor was stopped due to failure at 7,291 holes while the competitor drill failed after 7,291 holes despite machining at a lower speed and feed.

Tool	HY-PRO® CARB 5D	Competitor
Drill Size	Ø5/16	
Work Material	Ductile Cast Iron (25 HRC)	
Cutting Speed	375 SFM (4,580 RPM)	275 SFM (3,367 RPM)
Feed Rate	36 IPM (0.008 IPR)	22 IPM (0.0065 IPR)
Depth of Hole	1.2" (Blind)	
Coolant	Water-Soluble	
Machine	Horizontal Machining Center	

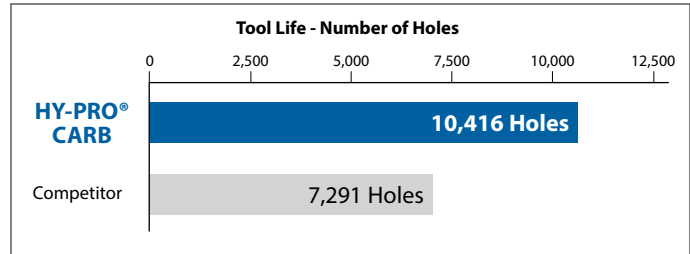

Superior Tool Life in Inconel

Excellent Performance Versus Competitors in Inconel

The HY-PRO® CARB drill dramatically outperformed the competitors in Inconel, machining 192 holes (136 linear inches) compared to the competition at just 12 and 2 holes.

Tool	HY-PRO® CARB 3D	Competitor A	Competitor B
Drill Size	Ø10.2mm		
Work Material	Inconel		
Cutting Speed	59 SFM (561 RPM)		
Feed Rate	2.6 IPM (0.0046 IPR)		
Depth of Hole	18 mm (Blind)		
Coolant	Water-Soluble		
Machine	Vertical Machining Center		

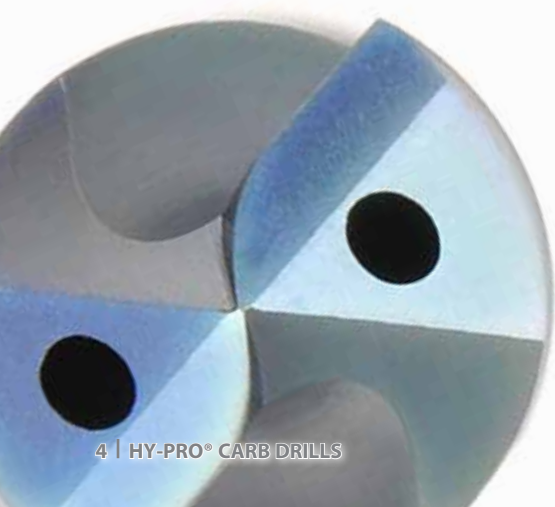
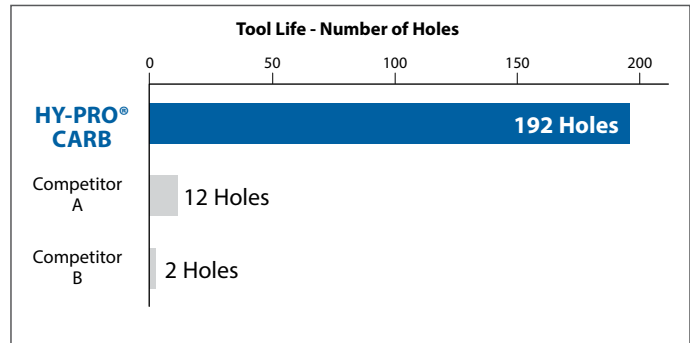

List HP243

3D



SPEED FEED P22	CARBIDE	WD1	30°	SHANK h6
--------------------------	----------------	------------	------------	--------------------

Cutting Diameter Tolerance (m7)		
Size	mm	inch
1<D≤3	+0.002 / +0.012	+0.0001 / +0.0005
3<D≤6	+0.004 / +0.016	+0.0002 / +0.0006
6<D≤10	+0.006 / +0.021	+0.0002 / +0.0008
10<D≤18	+0.007 / +0.025	+0.0003 / +0.0010
18<D≤20	+0.008 / +0.029	+0.0003 / +0.0011

EDP Number	Diameter					Flute Length FL	Overall Length L	Shank Diameter d
	Fractional Size	Wire Gage	Letter Size	mm	Inch			
HP243-0394	-	-	-	1.00	0.0394	7	35	3
HP243-0433	-	-	-	1.10	0.0433	7	35	3
HP243-0469	3/64	-	-	1.19	0.0469	8	35	3
HP243-0472	-	-	-	1.20	0.0472	8	35	3
HP243-0512	-	-	-	1.30	0.0512	8	35	3
HP243-0551	-	-	-	1.40	0.0551	9	35	3
HP243-0591	-	-	-	1.50	0.0591	9	40	3
HP243-0626	1/16	-	-	1.59	0.0626	10	40	3
HP243-0630	-	-	-	1.60	0.0630	10	40	3
HP243-0669	-	-	-	1.70	0.0669	10	40	3
HP243-0709	-	-	-	1.80	0.0709	11	40	3
HP243-0748	-	-	-	1.90	0.0748	11	40	3
HP243-0780	5/64	-	-	1.98	0.0780	13	45	3
HP243-0787	-	-	-	2.00	0.0787	13	45	3
HP243-0827	-	-	-	2.10	0.0827	13	45	3
HP243-0866	-	-	-	2.20	0.0866	13	45	3
HP243-0906	-	-	-	2.30	0.0906	13	45	3
HP243-0937	3/32	-	-	2.38	0.0937	15	45	3
HP243-0945	-	-	-	2.40	0.0945	15	45	3
HP243-0984	-	-	-	2.50	0.0984	15	50	3
HP243-1024	-	-	-	2.60	0.1024	15	50	3
HP243-1063	-	-	-	2.70	0.1063	17	50	3
HP243-1094	7/64	-	-	2.78	0.1094	17	50	3
HP243-1102	-	-	-	2.80	0.1102	17	50	3
HP243-1142	-	-	-	2.90	0.1142	17	50	3
HP243-1181	-	-	-	3.00	0.1181	20	62	6
HP243-1220	-	-	-	3.10	0.1220	20	62	6
HP243-1248	1/8	-	-	3.17	0.1248	20	62	6
HP243-1260	-	-	-	3.20	0.1260	20	62	6
HP243-1299	-	-	-	3.30	0.1299	20	62	6
HP243-1339	-	-	-	3.40	0.1339	20	62	6
HP243-1378	-	-	-	3.50	0.1378	20	62	6
HP243-1406	9/64	-	-	3.57	0.1406	20	62	6
HP243-1417	-	-	-	3.60	0.1417	20	62	6
HP243-1457	-	-	-	3.70	0.1457	20	62	6
HP243-1496	-	25	-	3.80	0.1496	24	66	6
HP243-1535	-	-	-	3.90	0.1535	24	66	6
HP243-1563	5/32	-	-	3.97	0.1563	24	66	6
HP243-1575	-	-	-	4.00	0.1575	24	66	6
HP243-1610	-	20	-	4.09	0.1610	24	66	6
HP243-1614	-	-	-	4.10	0.1614	24	66	6
HP243-1654	-	-	-	4.20	0.1654	24	66	6
HP243-1693	-	-	-	4.30	0.1693	24	66	6
HP243-1720	11/64	-	-	4.37	0.1720	24	66	6
HP243-1732	-	-	-	4.40	0.1732	24	66	6
HP243-1772	-	16	-	4.50	0.1772	24	66	6
HP243-1811	-	-	-	4.60	0.1811	24	66	6
HP243-1831	-	-	-	4.65	0.1831	24	66	6
HP243-1850	-	13	-	4.70	0.1850	24	66	6
HP243-1874	3/16	-	-	4.76	0.1874	28	66	6

Packed: 1 pc.
Available WD1 Coating Only.

[continued on next page](#)

Work Material																	
List No.	P					M			K	N		S		H			
	Carbon Steels			Alloy Steels 4140 4340	Die Steels 400	Stainless Steels			Cast Iron	Aluminum		Nickel Alloy Inconel	Titanium 6Al4V (30 HRC)	Hardened Steels			
	Low 1010 1018	Med. 1035 1045	High 1065			300	400	17-4 PH		6061 7075	Casting			~35 HRC	35-45 HRC	45-50 HRC	50-70 HRC
HP243	<input checked="" type="checkbox"/>	<input checked="" type="checkbox"/>	<input checked="" type="checkbox"/>	<input checked="" type="checkbox"/>	<input checked="" type="checkbox"/>				<input checked="" type="checkbox"/>	<input type="checkbox"/>			<input checked="" type="checkbox"/>	<input type="checkbox"/>			

good best



List HP243

3D



SPEED FEED	CARBIDE	WD1	30°	SHANK
P22				h6

Cutting Diameter Tolerance (m7)		
Size	mm	inch
1≤D≤3	+0.002 / +0.012	+0.0001 / +0.0005
3<D≤6	+0.004 / +0.016	+0.0002 / +0.0006
6<D≤10	+0.006 / +0.021	+0.0002 / +0.0008
10<D≤18	+0.007 / +0.025	+0.0003 / +0.0010
18<D≤20	+0.008 / +0.029	+0.0003 / +0.0011

EDP Number	Diameter					Flute Length FL	Overall Length L	Shank Diameter d
	Fractional Size	Wire Gage	Letter Size	mm	Inch			
HP243-1890	-	12	-	4.80	0.1890	28	66	6
HP243-1929	-	-	-	4.90	0.1929	28	66	6
HP243-1969	-	-	-	5.00	0.1969	28	66	6
HP243-2008	-	-	-	5.10	0.2008	28	66	6
HP243-2031	13/64	-	-	5.16	0.2031	28	66	6
HP243-2047	-	-	-	5.20	0.2047	28	66	6
HP243-2087	-	-	-	5.30	0.2087	28	66	6
HP243-2126	-	-	-	5.40	0.2126	28	66	6
HP243-2130	-	3	-	5.41	0.2130	28	66	6
HP243-2165	-	-	-	5.50	0.2165	28	66	6
HP243-2189	7/32	-	-	5.56	0.2189	28	66	6
HP243-2205	-	-	-	5.60	0.2205	28	66	6
HP243-2244	-	-	-	5.70	0.2244	28	66	6
HP243-2283	-	-	-	5.80	0.2283	28	66	6
HP243-2323	-	-	-	5.90	0.2323	28	66	6
HP243-2343	15/64	-	-	5.95	0.2343	28	66	6
HP243-2362	-	-	-	6.00	0.2362	28	66	6
HP243-2402	-	-	-	6.10	0.2402	34	79	8
HP243-2441	-	-	-	6.20	0.2441	34	79	8
HP243-2480	-	-	-	6.30	0.2480	34	79	8
HP243-2500	1/4	-	E	6.35	0.2500	34	79	8
HP243-2520	-	-	-	6.40	0.2520	34	79	8
HP243-2559	-	-	-	6.50	0.2559	34	79	8
HP243-2571	-	-	F	6.53	0.2571	34	79	8
HP243-2598	-	-	-	6.60	0.2598	34	79	8
HP243-2638	-	-	-	6.70	0.2638	34	79	8
HP243-2657	17/64	-	-	6.75	0.2657	34	79	8
HP243-2677	-	-	-	6.80	0.2677	34	79	8
HP243-2717	-	-	I	6.90	0.2717	34	79	8
HP243-2756	-	-	-	7.00	0.2756	34	79	8
HP243-2795	-	-	-	7.10	0.2795	41	79	8
HP243-2811	9/32	-	-	7.14	0.2811	41	79	8
HP243-2835	-	-	-	7.20	0.2835	41	79	8
HP243-2874	-	-	-	7.30	0.2874	41	79	8
HP243-2913	-	-	-	7.40	0.2913	41	79	8
HP243-2953	-	-	-	7.50	0.2953	41	79	8
HP243-2969	19/64	-	-	7.54	0.2969	41	79	8
HP243-2992	-	-	-	7.60	0.2992	41	79	8
HP243-3031	-	-	-	7.70	0.3031	41	79	8
HP243-3071	-	-	-	7.80	0.3071	41	79	8
HP243-3110	-	-	-	7.90	0.3110	41	79	8
HP243-3126	5/16	-	-	7.94	0.3126	41	79	8
HP243-3150	-	-	-	8.00	0.3150	41	79	8
HP243-3189	-	-	-	8.10	0.3189	47	89	10
HP243-3228	-	-	P	8.20	0.3228	47	89	10
HP243-3268	-	-	-	8.30	0.3268	47	89	10
HP243-3280	21/64	-	-	8.33	0.3280	47	89	10
HP243-3307	-	-	-	8.40	0.3307	47	89	10
HP243-3319	-	-	Q	8.43	0.3319	47	89	10
HP243-3346	-	-	-	8.50	0.3346	47	89	10
HP243-3386	-	-	-	8.60	0.3386	47	89	10
HP243-3425	-	-	-	8.70	0.3425	47	89	10
HP243-3437	11/32	-	-	8.73	0.3437	47	89	10
HP243-3465	-	-	-	8.80	0.3465	47	89	10
HP243-3504	-	-	-	8.90	0.3504	47	89	10
HP243-3543	-	-	-	9.00	0.3543	47	89	10
HP243-3583	-	-	-	9.10	0.3583	47	89	10
HP243-3594	23/64	-	-	9.13	0.3594	47	89	10
HP243-3622	-	-	-	9.20	0.3622	47	89	10
HP243-3642	-	-	-	9.25	0.3642	47	89	10
HP243-3661	-	-	-	9.30	0.3661	47	89	10

Packed: 1 pc.
Available WD1 Coating Only.



List HP243

3D



EDP Number	Diameter					Flute Length	Overall Length	Shank Diameter
	Fractional Size	Wire Gage	Letter Size	mm	Inch	FL	L	d
HP243-3701	-	-	-	9.40	0.3701	47	89	10
HP243-3740	-	-	-	9.50	0.3740	47	89	10
HP243-3748	3/8	-	-	9.52	0.3748	47	89	10
HP243-3780	-	-	-	9.60	0.3780	47	89	10
HP243-3819	-	-	-	9.70	0.3819	47	89	10
HP243-3858	-	-	W	9.80	0.3858	47	89	10
HP243-3898	-	-	-	9.90	0.3898	47	89	10
HP243-3906	25/64	-	-	9.92	0.3906	47	89	10
HP243-3937	-	-	-	10.00	0.3937	47	89	10
HP243-3976	-	-	-	10.10	0.3976	55	102	12
HP243-4016	-	-	-	10.20	0.4016	55	102	12
HP243-4055	-	-	-	10.30	0.4055	55	102	12
HP243-4063	13/32	-	-	10.32	0.4063	55	102	12
HP243-4094	-	-	-	10.40	0.4094	55	102	12
HP243-4134	-	-	-	10.50	0.4134	55	102	12
HP243-4173	-	-	-	10.60	0.4173	55	102	12
HP243-4213	-	-	-	10.70	0.4213	55	102	12
HP243-4220	27/64	-	-	10.72	0.4220	55	102	12
HP243-4252	-	-	-	10.80	0.4252	55	102	12
HP243-4291	-	-	-	10.90	0.4291	55	102	12
HP243-4331	-	-	-	11.00	0.4331	55	102	12
HP243-4370	-	-	-	11.10	0.4370	55	102	12
HP243-4374	7/16	-	-	11.11	0.4374	55	102	12
HP243-4409	-	-	-	11.20	0.4409	55	102	12
HP243-4449	-	-	-	11.30	0.4449	55	102	12
HP243-4488	-	-	-	11.40	0.4488	55	102	12
HP243-4528	-	-	-	11.50	0.4528	55	102	12
HP243-4531	29/64	-	-	11.51	0.4531	55	102	12
HP243-4567	-	-	-	11.60	0.4567	55	102	12
HP243-4606	-	-	-	11.70	0.4606	55	102	12
HP243-4646	-	-	-	11.80	0.4646	55	102	12
HP243-4685	-	-	-	11.90	0.4685	55	102	12
HP243-4689	15/32	-	-	11.91	0.4689	55	102	12
HP243-4724	-	-	-	12.00	0.4724	55	102	12
HP243-4764	-	-	-	12.10	0.4764	60	107	14
HP243-4803	-	-	-	12.20	0.4803	60	107	14
HP243-4843	31/64	-	-	12.30	0.4843	60	107	14
HP243-4882	-	-	-	12.40	0.4882	60	107	14
HP243-4921	-	-	-	12.50	0.4921	60	107	14
HP243-4961	-	-	-	12.60	0.4961	60	107	14
HP243-5000	1/2	-	-	12.70	0.5000	60	107	14
HP243-5039	-	-	-	12.80	0.5039	60	107	14
HP243-5079	-	-	-	12.90	0.5079	60	107	14
HP243-5118	-	-	-	13.00	0.5118	60	107	14
HP243-5157	33/64	-	-	13.10	0.5157	60	107	14
HP243-5197	-	-	-	13.20	0.5197	60	107	14
HP243-5236	-	-	-	13.30	0.5236	60	107	14
HP243-5276	-	-	-	13.40	0.5276	60	107	14
HP243-5311	17/32	-	-	13.49	0.5311	60	107	14
HP243-5315	-	-	-	13.50	0.5315	60	107	14
HP243-5394	-	-	-	13.70	0.5394	60	107	14
HP243-5512	-	-	-	14.00	0.5512	60	107	14
HP243-5626	9/16	-	-	14.29	0.5626	65	115	16
HP243-5709	-	-	-	14.50	0.5709	65	115	16
HP243-5780	37/64	-	-	14.68	0.5780	65	115	16
HP243-5787	-	-	-	14.70	0.5787	65	115	16
HP243-5906	-	-	-	15.00	0.5906	65	115	16

Packed: 1 pc.
Available WD1 Coating Only.

▶ continued on next page ▶

Work Material																	
List No.	P					M			K	N		S		H			
	Carbon Steels			Alloy Steels	Die Steels	Stainless Steels			Cast Iron	Aluminum		Nickel Alloy	Titanium	Hardened Steels			
	Low	Med.	High	4140 4340	400	300	400	17-4 PH		6061 7075	Casting	Inconel	6Al4V (30 HRC)	~35 HRC	35-45 HRC	45-50 HRC	50-70 HRC
HP243	☐	☐	☐	☐	☐				☐		☐		☐	☐			

☐ good ☐ best



List HP243

3D



SPEED FEED P22	CARBIDE WD1	30°	SHANK h6
-------------------	----------------	-----	-------------

Cutting Diameter Tolerance (m7)		
Size	mm	inch
1 ≤ D ≤ 3	+0.002 / +0.012	+0.0001 / +0.0005
3 < D ≤ 6	+0.004 / +0.016	+0.0002 / +0.0006
6 < D ≤ 10	+0.006 / +0.021	+0.0002 / +0.0008
10 < D ≤ 18	+0.007 / +0.025	+0.0003 / +0.0010
18 < D ≤ 20	+0.008 / +0.029	+0.0003 / +0.0011

EDP Number	Diameter					Flute Length FL	Overall Length L	Shank Diameter d
	Fractional Size	Wire Gage	Letter Size	mm	Inch			
HP243-5937	19/32	-	-	15.08	0.5937	65	115	16
HP243-6102	-	-	-	15.50	0.6102	65	115	16
HP243-6181	-	-	-	15.70	0.6181	65	115	16
HP243-6248	5/8	-	-	15.87	0.6248	65	115	16
HP243-6299	-	-	-	16.00	0.6299	65	115	16
HP243-6339	-	-	-	16.10	0.6339	73	123	18
HP243-6496	-	-	-	16.50	0.6496	73	123	18
HP243-6563	21/32	-	-	16.67	0.6563	73	123	18
HP243-6693	-	-	-	17.00	0.6693	73	123	18
HP243-6890	-	-	-	17.50	0.6890	73	123	18
HP243-7087	-	-	-	18.00	0.7087	73	123	18
HP243-7283	-	-	-	18.50	0.7283	79	131	20
HP243-7480	-	-	-	19.00	0.7480	79	131	20
HP243-7500	3/4	-	-	19.05	0.7500	79	131	20
HP243-7579	-	-	-	19.25	0.7579	79	131	20
HP243-7677	-	-	-	19.50	0.7677	79	131	20
HP243-7874	-	-	-	20.00	0.7874	79	131	20

Packed: 1 pc.
Available WD1 Coating Only.



Work Material																	
List No.	P					M			K	N		S		H			
	Carbon Steels			Alloy Steels 4140 4340	Die Steels 400	Stainless Steels			Cast Iron	Aluminum		Nickel Alloy Inconel	Titanium 6Al4V (30 HRC)	Hardened Steels			
	Low 1010 1018	Med. 1035 1045	High 1065			300	400	17-4 PH		6061 7075	Casting			~35 HRC	35-45 HRC	45-50 HRC	50-70 HRC
HP243	<input checked="" type="checkbox"/>	<input checked="" type="checkbox"/>	<input checked="" type="checkbox"/>	<input checked="" type="checkbox"/>	<input checked="" type="checkbox"/>				<input checked="" type="checkbox"/>		<input type="checkbox"/>			<input checked="" type="checkbox"/>	<input type="checkbox"/>		

good best



List HP245

5D

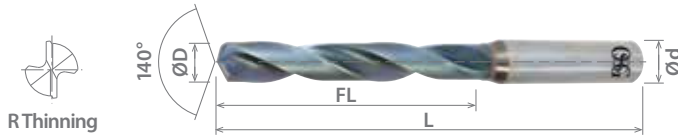

SPEED FEED P22	CARBIDE	WD1	30°	SHANK h6
--------------------------	----------------	------------	------------	--------------------

Cutting Diameter Tolerance (m7)		
Size	mm	inch
1≤D≤3	+0.002 / +0.012	+0.0001 / +0.0005
3<D≤6	+0.004 / +0.016	+0.0002 / +0.0006
6<D≤10	+0.006 / +0.021	+0.0002 / +0.0008
10<D≤18	+0.007 / +0.025	+0.0003 / +0.0010
18<D≤20	+0.008 / +0.029	+0.0003 / +0.0011

EDP Number	Diameter					Flute Length FL	Overall Length L	Shank Diameter d
	Fractional Size	Wire Gage	Letter Size	mm	Inch			
HP245-0394	-	-	-	1.00	0.0394	9	38	3
HP245-0433	-	-	-	1.10	0.0433	9	38	3
HP245-0469	3/64	-	-	1.19	0.0469	11	38	3
HP245-0472	-	-	-	1.20	0.0472	11	38	3
HP245-0512	-	-	-	1.30	0.0512	11	38	3
HP245-0551	-	-	-	1.40	0.0551	12	38	3
HP245-0591	-	-	-	1.50	0.0591	12	45	3
HP245-0626	1/16	-	-	1.59	0.0626	14	45	3
HP245-0630	-	-	-	1.60	0.0630	14	45	3
HP245-0669	-	-	-	1.70	0.0669	14	45	3
HP245-0709	-	-	-	1.80	0.0709	16	45	3
HP245-0748	-	-	-	1.90	0.0748	16	45	3
HP245-0780	5/64	-	-	1.98	0.0780	18	50	3
HP245-0787	-	-	-	2.00	0.0787	18	50	3
HP245-0827	-	-	-	2.10	0.0827	18	50	3
HP245-0866	-	-	-	2.20	0.0866	20	52	3
HP245-0906	-	-	-	2.30	0.0906	20	52	3
HP245-0937	3/32	-	-	2.38	0.0937	22	52	3
HP245-0945	-	-	-	2.40	0.0945	22	52	3
HP245-0984	-	-	-	2.50	0.0984	22	56	3
HP245-1024	-	-	-	2.60	0.1024	22	56	3
HP245-1063	-	-	-	2.70	0.1063	23	56	3
HP245-1094	7/64	-	-	2.78	0.1094	23	56	3
HP245-1102	-	-	-	2.80	0.1102	23	56	3
HP245-1142	-	-	-	2.90	0.1142	23	56	3
HP245-1181	-	-	-	3.00	0.1181	28	66	6
HP245-1220	-	-	-	3.10	0.1220	28	66	6
HP245-1248	1/8	-	-	3.17	0.1248	28	66	6
HP245-1260	-	-	-	3.20	0.1260	28	66	6
HP245-1299	-	-	-	3.30	0.1299	28	66	6
HP245-1339	-	-	-	3.40	0.1339	28	66	6
HP245-1378	-	-	-	3.50	0.1378	28	66	6
HP245-1406	9/64	-	-	3.57	0.1406	28	66	6
HP245-1417	-	-	-	3.60	0.1417	28	66	6
HP245-1457	-	-	-	3.70	0.1457	28	66	6
HP245-1496	-	25	-	3.80	0.1496	36	74	6
HP245-1535	-	-	-	3.90	0.1535	36	74	6
HP245-1563	5/32	-	-	3.97	0.1563	36	74	6
HP245-1575	-	-	-	4.00	0.1575	36	74	6
HP245-1610	-	20	-	4.09	0.1610	36	74	6
HP245-1614	-	-	-	4.10	0.1614	36	74	6
HP245-1654	-	-	-	4.20	0.1654	36	74	6
HP245-1693	-	-	-	4.30	0.1693	36	74	6
HP245-1720	11/64	-	-	4.37	0.1720	36	74	6
HP245-1732	-	-	-	4.40	0.1732	36	74	6
HP245-1772	-	16	-	4.50	0.1772	36	74	6
HP245-1811	-	-	-	4.60	0.1811	36	74	6
HP245-1831	-	-	-	4.65	0.1831	36	74	6
HP245-1850	-	13	-	4.70	0.1850	36	74	6
HP245-1874	3/16	-	-	4.76	0.1874	44	82	6
HP245-1890	-	12	-	4.80	0.1890	44	82	6
HP245-1929	-	-	-	4.90	0.1929	44	82	6

Packed: 1 pc.
Available WD1 Coating Only.

continued on next page

List No.	Work Material																
	P					M			K	N		S		H			
	Carbon Steels			Alloy Steels	Die Steels	Stainless Steels			Cast Iron	Aluminum		Nickel Alloy	Titanium	Hardened Steels			
	Low	Med.	High	4140 4340	400	300	400	17-4 PH			6061 7075	Casting	Inconel	6Al4V (30 HRC)	~35 HRC	35-45 HRC	45-50 HRC
HP245	<input checked="" type="checkbox"/>	<input checked="" type="checkbox"/>	<input checked="" type="checkbox"/>	<input checked="" type="checkbox"/>	<input checked="" type="checkbox"/>				<input checked="" type="checkbox"/>		<input type="checkbox"/>			<input checked="" type="checkbox"/>	<input type="checkbox"/>		

good best



List HP245

5D

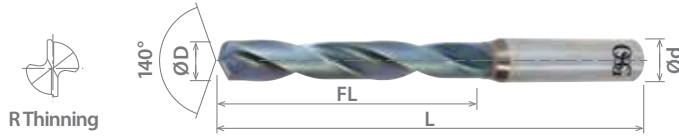

SPEED FEED	CARBIDE	WD1	30°	SHANK
P22				h6

Cutting Diameter Tolerance (m7)		
Size	mm	inch
1 ≤ D ≤ 3	+0.002 / +0.012	+0.0001 / +0.0005
3 < D ≤ 6	+0.004 / +0.016	+0.0002 / +0.0006
6 < D ≤ 10	+0.006 / +0.021	+0.0002 / +0.0008
10 < D ≤ 18	+0.007 / +0.025	+0.0003 / +0.0010
18 < D ≤ 20	+0.008 / +0.029	+0.0003 / +0.0011

EDP Number	Diameter					Flute Length FL	Overall Length L	Shank Diameter d
	Fractional Size	Wire Gage	Letter Size	mm	Inch			
HP245-1969	-	-	-	5.00	0.1969	44	82	6
HP245-2008	-	-	-	5.10	0.2008	44	82	6
HP245-2031	13/64	-	-	5.16	0.2031	44	82	6
HP245-2047	-	-	-	5.20	0.2047	44	82	6
HP245-2087	-	-	-	5.30	0.2087	44	82	6
HP245-2126	-	-	-	5.40	0.2126	44	82	6
HP245-2130	-	3	-	5.41	0.2130	44	82	6
HP245-2165	-	-	-	5.50	0.2165	44	82	6
HP245-2189	7/32	-	-	5.56	0.2189	44	82	6
HP245-2205	-	-	-	5.60	0.2205	44	82	6
HP245-2244	-	-	-	5.70	0.2244	44	82	6
HP245-2283	-	-	-	5.80	0.2283	44	82	6
HP245-2323	-	-	-	5.90	0.2323	44	82	6
HP245-2343	15/64	-	-	5.95	0.2343	44	82	6
HP245-2362	-	-	-	6.00	0.2362	44	82	6
HP245-2402	-	-	-	6.10	0.2402	53	91	8
HP245-2441	-	-	-	6.20	0.2441	53	91	8
HP245-2480	-	-	-	6.30	0.2480	53	91	8
HP245-2500	1/4	-	E	6.35	0.2500	53	91	8
HP245-2520	-	-	-	6.40	0.2520	53	91	8
HP245-2559	-	-	-	6.50	0.2559	53	91	8
HP245-2571	-	-	F	6.53	0.2571	53	91	8
HP245-2598	-	-	-	6.60	0.2598	53	91	8
HP245-2638	-	-	-	6.70	0.2638	53	91	8
HP245-2657	17/64	-	-	6.75	0.2657	53	91	8
HP245-2677	-	-	-	6.80	0.2677	53	91	8
HP245-2717	-	-	I	6.90	0.2717	53	91	8
HP245-2756	-	-	-	7.00	0.2756	53	91	8
HP245-2795	-	-	-	7.10	0.2795	53	91	8
HP245-2811	9/32	-	-	7.14	0.2811	53	91	8
HP245-2835	-	-	-	7.20	0.2835	53	91	8
HP245-2874	-	-	-	7.30	0.2874	53	91	8
HP245-2913	-	-	-	7.40	0.2913	53	91	8
HP245-2953	-	-	-	7.50	0.2953	53	91	8
HP245-2969	19/64	-	-	7.54	0.2969	53	91	8
HP245-2992	-	-	-	7.60	0.2992	53	91	8
HP245-3031	-	-	-	7.70	0.3031	53	91	8
HP245-3071	-	-	-	7.80	0.3071	53	91	8
HP245-3110	-	-	-	7.90	0.3110	53	91	8
HP245-3126	5/16	-	-	7.94	0.3126	53	91	8
HP245-3150	-	-	-	8.00	0.3150	53	91	8
HP245-3189	-	-	-	8.10	0.3189	61	103	10
HP245-3228	-	-	P	8.20	0.3228	61	103	10
HP245-3268	-	-	-	8.30	0.3268	61	103	10
HP245-3280	21/64	-	-	8.33	0.3280	61	103	10
HP245-3307	-	-	-	8.40	0.3307	61	103	10
HP245-3319	-	-	Q	8.43	0.3319	61	103	10
HP245-3346	-	-	-	8.50	0.3346	61	103	10
HP245-3386	-	-	-	8.60	0.3386	61	103	10
HP245-3425	-	-	-	8.70	0.3425	61	103	10
HP245-3437	11/32	-	-	8.73	0.3437	61	103	10
HP245-3465	-	-	-	8.80	0.3465	61	103	10
HP245-3504	-	-	-	8.90	0.3504	61	103	10
HP245-3543	-	-	-	9.00	0.3543	61	103	10
HP245-3583	-	-	-	9.10	0.3583	61	103	10
HP245-3594	23/64	-	-	9.13	0.3594	61	103	10
HP245-3622	-	-	-	9.20	0.3622	61	103	10
HP245-3642	-	-	-	9.25	0.3642	61	103	10
HP245-3661	-	-	-	9.30	0.3661	61	103	10
HP245-3701	-	-	-	9.40	0.3701	61	103	10
HP245-3740	-	-	-	9.50	0.3740	61	103	10
HP245-3748	3/8	-	-	9.52	0.3748	61	103	10

Packed: 1 pc.
Available WD1 Coating Only.



List HP245

5D

SPEED FEED P22	CARBIDE	WD1	30°	SHANK h6
--------------------------	----------------	------------	------------	--------------------

EDP Number	Diameter					Flute Length FL	Overall Length L	Shank Diameter d
	Fractional Size	Wire Gage	Letter Size	mm	Inch			
HP245-3780	-	-	-	9.60	0.3780	61	103	10
HP245-3819	-	-	-	9.70	0.3819	61	103	10
HP245-3858	-	-	W	9.80	0.3858	61	103	10
HP245-3898	-	-	-	9.90	0.3898	61	103	10
HP245-3906	25/64	-	-	9.92	0.3906	61	103	10
HP245-3937	-	-	-	10.00	0.3937	61	103	10
HP245-3976	-	-	-	10.10	0.3976	71	118	12
HP245-4016	-	-	-	10.20	0.4016	71	118	12
HP245-4055	-	-	-	10.30	0.4055	71	118	12
HP245-4063	13/32	-	-	10.32	0.4063	71	118	12
HP245-4094	-	-	-	10.40	0.4094	71	118	12
HP245-4134	-	-	-	10.50	0.4134	71	118	12
HP245-4173	-	-	-	10.60	0.4173	71	118	12
HP245-4213	-	-	-	10.70	0.4213	71	118	12
HP245-4220	27/64	-	-	10.72	0.4220	71	118	12
HP245-4252	-	-	-	10.80	0.4252	71	118	12
HP245-4291	-	-	-	10.90	0.4291	71	118	12
HP245-4331	-	-	-	11.00	0.4331	71	118	12
HP245-4370	-	-	-	11.10	0.4370	71	118	12
HP245-4374	7/16	-	-	11.11	0.4374	71	118	12
HP245-4409	-	-	-	11.20	0.4409	71	118	12
HP245-4449	-	-	-	11.30	0.4449	71	118	12
HP245-4488	-	-	-	11.40	0.4488	71	118	12
HP245-4528	-	-	-	11.50	0.4528	71	118	12
HP245-4531	29/64	-	-	11.51	0.4531	71	118	12
HP245-4567	-	-	-	11.60	0.4567	71	118	12
HP245-4606	-	-	-	11.70	0.4606	71	118	12
HP245-4646	-	-	-	11.80	0.4646	71	118	12
HP245-4685	-	-	-	11.90	0.4685	71	118	12
HP245-4689	15/32	-	-	11.91	0.4689	71	118	12
HP245-4724	-	-	-	12.00	0.4724	71	118	12
HP245-4764	-	-	-	12.10	0.4764	77	124	14
HP245-4803	-	-	-	12.20	0.4803	77	124	14
HP245-4843	31/64	-	-	12.30	0.4843	77	124	14
HP245-4882	-	-	-	12.40	0.4882	77	124	14
HP245-4921	-	-	-	12.50	0.4921	77	124	14
HP245-4961	-	-	-	12.60	0.4961	77	124	14
HP245-5000	1/2	-	-	12.70	0.5000	77	124	14
HP245-5039	-	-	-	12.80	0.5039	77	124	14
HP245-5079	-	-	-	12.90	0.5079	77	124	14
HP245-5118	-	-	-	13.00	0.5118	77	124	14
HP245-5157	33/64	-	-	13.10	0.5157	77	124	14
HP245-5197	-	-	-	13.20	0.5197	77	124	14
HP245-5236	-	-	-	13.30	0.5236	77	124	14
HP245-5394	-	-	-	13.70	0.5394	77	124	14
HP245-5276	-	-	-	13.40	0.5276	77	124	14
HP245-5311	17/32	-	-	13.49	0.5311	77	124	14
HP245-5315	-	-	-	13.50	0.5315	77	124	14
HP245-5512	-	-	-	14.00	0.5512	77	124	14
HP245-5626	9/16	-	-	14.29	0.5626	83	133	16
HP245-5709	-	-	-	14.50	0.5709	83	133	16
HP245-5780	37/64	-	-	14.68	0.5780	83	133	16
HP245-5787	-	-	-	14.70	0.5787	83	133	16
HP245-5906	-	-	-	15.00	0.5906	83	133	16
HP245-5937	19/32	-	-	15.08	0.5937	83	133	16
HP245-6102	-	-	-	15.50	0.6102	83	133	16
HP245-6181	-	-	-	15.70	0.6181	83	133	16
HP245-6248	5/8	-	-	15.87	0.6248	83	133	16
HP245-6299	-	-	-	16.00	0.6299	83	133	16

Packed: 1 pc.
Available WD1 Coating Only.

continued on next page

Work Material																	
List No.	P					M			K Cast Iron	N		S		H			
	Carbon Steels			Alloy Steels 4140 4340	Die Steels 400	Stainless Steels				Aluminum		Nickel Alloy Inconel	Titanium 6Al4V (30 HRC)	Hardened Steels			
	Low 1010 1018	Med. 1035 1045	High 1065			300	400	17-4 PH		6061 7075	Casting			~35 HRC	35-45 HRC	45-50 HRC	50-70 HRC
HP245	<input checked="" type="checkbox"/>	<input checked="" type="checkbox"/>	<input checked="" type="checkbox"/>	<input checked="" type="checkbox"/>	<input checked="" type="checkbox"/>				<input checked="" type="checkbox"/>	<input type="checkbox"/>			<input checked="" type="checkbox"/>	<input type="checkbox"/>			

good best



List HP245

5D

SPEED FEED P22	CARBIDE	WD1	30°	SHANK h6
----------------------	---------	-----	-----	-------------



Cutting Diameter Tolerance (m7)		
Size	mm	inch
1 ≤ D ≤ 3	+0.002 / +0.012	+0.0001 / +0.0005
3 < D ≤ 6	+0.004 / +0.016	+0.0002 / +0.0006
6 < D ≤ 10	+0.006 / +0.021	+0.0002 / +0.0008
10 < D ≤ 18	+0.007 / +0.025	+0.0003 / +0.0010
18 < D ≤ 20	+0.008 / +0.029	+0.0003 / +0.0011

EDP Number	Diameter					Flute Length	Overall Length	Shank Diameter
	Fractional Size	Wire Gage	Letter Size	mm	Inch			
HP245-6339				16.10	0.6339	93	143	18
HP245-6496	-	-	-	16.50	0.6496	93	143	18
HP245-6563	21/32	-	-	16.67	0.6563	93	143	18
HP245-6693	-	-	-	17.00	0.6693	93	143	18
HP245-6890	-	-	-	17.50	0.6890	93	143	18
HP245-7087	-	-	-	18.00	0.7087	93	143	18
HP245-7283	-	-	-	18.50	0.7283	101	153	20
HP245-7480	-	-	-	19.00	0.7480	101	153	20
HP245-7500	3/4	-	-	19.05	0.7500	101	153	20
HP245-7579	-	-	-	19.25	0.7579	101	153	20
HP245-7677	-	-	-	19.50	0.7677	101	153	20
HP245-7874	-	-	-	20.00	0.7874	101	153	20

Packed: 1 pc.
Available WD1 Coating Only.



Work Material																	
List No.	P					M			K	N		S		H			
	Carbon Steels			Alloy Steels	Die Steels	Stainless Steels			Cast Iron	Aluminum		Nickel Alloy	Titanium	Hardened Steels			
	Low	Med.	High			300	400	17-4 PH		6061	Casting			7075	6Al4V (30 HRC)	~35 HRC	35-45 HRC
HP245	<input checked="" type="checkbox"/>	<input checked="" type="checkbox"/>	<input checked="" type="checkbox"/>	<input checked="" type="checkbox"/>	<input checked="" type="checkbox"/>				<input checked="" type="checkbox"/>		<input type="checkbox"/>			<input checked="" type="checkbox"/>	<input type="checkbox"/>		

good best



List HP253

3D, Coolant-Through

SPEED FEED P23	CARBIDE	WD1	30°	SHANK h6
--------------------------	----------------	------------	------------	--------------------



Cutting Diameter Tolerance (m7)		
Size	mm	inch
D=3	+0.002 / +0.012	+0.0001 / +0.0005
3<D≤6	+0.004 / +0.016	+0.0002 / +0.0006
6<D≤10	+0.006 / +0.021	+0.0002 / +0.0008
10<D≤18	+0.007 / +0.025	+0.0003 / +0.0010
18<D≤20	+0.008 / +0.029	+0.0003 / +0.0011

EDP Number	Diameter					Flute Length FL	Overall Length L	Shank Diameter d
	Fractional Size	Wire Gage	Letter Size	mm	Inch			
HP253-1181	-	-	-	3.00	0.1181	20	62	6
HP253-1220	-	-	-	3.10	0.1220	20	62	6
HP253-1248	1/8	-	-	3.17	0.1248	20	62	6
HP253-1260	-	-	-	3.20	0.1260	20	62	6
HP253-1299	-	-	-	3.30	0.1299	20	62	6
HP253-1339	-	-	-	3.40	0.1339	20	62	6
HP253-1378	-	-	-	3.50	0.1378	20	62	6
HP253-1406	9/64	-	-	3.57	0.1406	20	62	6
HP253-1417	-	-	-	3.60	0.1417	20	62	6
HP253-1457	-	-	-	3.70	0.1457	20	62	6
HP253-1496	-	25	-	3.80	0.1496	24	66	6
HP253-1535	-	-	-	3.90	0.1535	24	66	6
HP253-1563	5/32	-	-	3.97	0.1563	24	66	6
HP253-1575	-	-	-	4.00	0.1575	24	66	6
HP253-1610	-	20	-	4.09	0.1610	24	66	6
HP253-1614	-	-	-	4.10	0.1614	24	66	6
HP253-1654	-	-	-	4.20	0.1654	24	66	6
HP253-1693	-	-	-	4.30	0.1693	24	66	6
HP253-1720	11/64	-	-	4.37	0.1720	24	66	6
HP253-1732	-	-	-	4.40	0.1732	24	66	6
HP253-1772	-	16	-	4.50	0.1772	24	66	6
HP253-1811	-	-	-	4.60	0.1811	24	66	6
HP253-1831	-	-	-	4.65	0.1831	24	66	6
HP253-1850	-	13	-	4.70	0.1850	24	66	6
HP253-1874	3/16	-	-	4.76	0.1874	28	66	6
HP253-1890	-	12	-	4.80	0.1890	28	66	6
HP253-1929	-	-	-	4.90	0.1929	28	66	6
HP253-1969	-	-	-	5.00	0.1969	28	66	6
HP253-2008	-	-	-	5.10	0.2008	28	66	6
HP253-2031	13/64	-	-	5.16	0.2031	28	66	6
HP253-2047	-	-	-	5.20	0.2047	28	66	6
HP253-2087	-	-	-	5.30	0.2087	28	66	6
HP253-2126	-	-	-	5.40	0.2126	28	66	6
HP253-2130	-	3	-	5.41	0.2130	28	66	6
HP253-2165	-	-	-	5.50	0.2165	28	66	6
HP253-2189	7/32	-	-	5.56	0.2189	28	66	6
HP253-2205	-	-	-	5.60	0.2205	28	66	6
HP253-2244	-	-	-	5.70	0.2244	28	66	6
HP253-2283	-	-	-	5.80	0.2283	28	66	6
HP253-2323	-	-	-	5.90	0.2323	28	66	6
HP253-2343	15/64	-	-	5.95	0.2343	28	66	6
HP253-2362	-	-	-	6.00	0.2362	28	66	6
HP253-2402	-	-	-	6.10	0.2402	34	79	8
HP253-2441	-	-	-	6.20	0.2441	34	79	8
HP253-2480	-	-	-	6.30	0.2480	34	79	8
HP253-2500	1/4	-	E	6.35	0.2500	34	79	8
HP253-2520	-	-	-	6.40	0.2520	34	79	8
HP253-2559	-	-	-	6.50	0.2559	34	79	8
HP253-2571	-	-	F	6.53	0.2571	34	79	8
HP253-2598	-	-	-	6.60	0.2598	34	79	8
HP253-2638	-	-	-	6.70	0.2638	34	79	8
HP253-2657	17/64	-	-	6.75	0.2657	34	79	8

Packed: 1 pc.
Available WD1 Coating Only.

continued on next page

Work Material																	
List No.	P					M			K	N		S		H			
	Carbon Steels			Alloy Steels 4140 4340	Die Steels 400	Stainless Steels			Cast Iron	Aluminum		Nickel Alloy Inconel	Titanium 6Al4V (30 HRC)	Hardened Steels			
	Low 1010 1018	Med. 1035 1045	High 1065			300	400	17-4 PH		6061 7075	Casting			~35 HRC	35-45 HRC	45-50 HRC	50-70 HRC
HP253	<input checked="" type="checkbox"/>	<input checked="" type="checkbox"/>	<input checked="" type="checkbox"/>	<input checked="" type="checkbox"/>	<input checked="" type="checkbox"/>	<input type="checkbox"/>	<input type="checkbox"/>	<input type="checkbox"/>	<input checked="" type="checkbox"/>	<input type="checkbox"/>	<input type="checkbox"/>	<input type="checkbox"/>	<input checked="" type="checkbox"/>	<input type="checkbox"/>	<input type="checkbox"/>	<input type="checkbox"/>	

good best



List HP253

3D, Coolant-Through



SPEED FEED P23	CARBIDE	WD1	30°	SHANK h6
--------------------------	----------------	------------	------------	--------------------

Cutting Diameter Tolerance (m7)		
Size	mm	inch
D=3	+0.002 / +0.012	+0.0001 / +0.0005
3<D≤6	+0.004 / +0.016	+0.0002 / +0.0006
6<D≤10	+0.006 / +0.021	+0.0002 / +0.0008
10<D≤18	+0.007 / +0.025	+0.0003 / +0.0010
18<D≤20	+0.008 / +0.029	+0.0003 / +0.0011

EDP Number	Diameter					Flute Length FL	Overall Length L	Shank Diameter d
	Fractional Size	Wire Gage	Letter Size	mm	Inch			
HP253-2677	-	-	-	6.80	0.2677	34	79	8
HP253-2717	-	-	I	6.90	0.2717	34	79	8
HP253-2756	-	-	-	7.00	0.2756	34	79	8
HP253-2795	-	-	-	7.10	0.2795	41	79	8
HP253-2811	9/32	-	-	7.14	0.2811	41	79	8
HP253-2835	-	-	-	7.20	0.2835	41	79	8
HP253-2874	-	-	-	7.30	0.2874	41	79	8
HP253-2913	-	-	-	7.40	0.2913	41	79	8
HP253-2953	-	-	-	7.50	0.2953	41	79	8
HP253-2969	19/64	-	-	7.54	0.2969	41	79	8
HP253-2992	-	-	-	7.60	0.2992	41	79	8
HP253-3031	-	-	-	7.70	0.3031	41	79	8
HP253-3071	-	-	-	7.80	0.3071	41	79	8
HP253-3110	-	-	-	7.90	0.3110	41	79	8
HP253-3126	5/16	-	-	7.94	0.3126	41	79	8
HP253-3150	-	-	-	8.00	0.3150	41	79	8
HP253-3189	-	-	-	8.10	0.3189	47	89	10
HP253-3228	-	-	P	8.20	0.3228	47	89	10
HP253-3268	-	-	-	8.30	0.3268	47	89	10
HP253-3280	21/64	-	-	8.33	0.3280	47	89	10
HP253-3307	-	-	-	8.40	0.3307	47	89	10
HP253-3319	-	-	Q	8.43	0.3319	47	89	10
HP253-3346	-	-	-	8.50	0.3346	47	89	10
HP253-3386	-	-	-	8.60	0.3386	47	89	10
HP253-3425	-	-	-	8.70	0.3425	47	89	10
HP253-3437	11/32	-	-	8.73	0.3437	47	89	10
HP253-3465	-	-	-	8.80	0.3465	47	89	10
HP253-3504	-	-	-	8.90	0.3504	47	89	10
HP253-3543	-	-	-	9.00	0.3543	47	89	10
HP253-3583	-	-	-	9.10	0.3583	47	89	10
HP253-3594	23/64	-	-	9.13	0.3594	47	89	10
HP253-3622	-	-	-	9.20	0.3622	47	89	10
HP253-3642	-	-	-	9.25	0.3642	47	89	10
HP253-3661	-	-	-	9.30	0.3661	47	89	10
HP253-3701	-	-	-	9.40	0.3701	47	89	10
HP253-3740	-	-	-	9.50	0.3740	47	89	10
HP253-3748	3/8	-	-	9.52	0.3748	47	89	10
HP253-3780	-	-	-	9.60	0.3780	47	89	10
HP253-3819	-	-	-	9.70	0.3819	47	89	10
HP253-3858	-	-	W	9.80	0.3858	47	89	10
HP253-3898	-	-	-	9.90	0.3898	47	89	10
HP253-3906	25/64	-	-	9.92	0.3906	47	89	10
HP253-3937	-	-	-	10.00	0.3937	47	89	10
HP253-3976	-	-	-	10.10	0.3976	55	102	12
HP253-4016	-	-	-	10.20	0.4016	55	102	12
HP253-4055	-	-	-	10.30	0.4055	55	102	12
HP253-4063	13/32	-	-	10.32	0.4063	55	102	12
HP253-4094	-	-	-	10.40	0.4094	55	102	12
HP253-4134	-	-	-	10.50	0.4134	55	102	12
HP253-4173	-	-	-	10.60	0.4173	55	102	12
HP253-4213	-	-	-	10.70	0.4213	55	102	12
HP253-4220	27/64	-	-	10.72	0.4220	55	102	12
HP253-4252	-	-	-	10.80	0.4252	55	102	12
HP253-4291	-	-	-	10.90	0.4291	55	102	12
HP253-4331	-	-	-	11.00	0.4331	55	102	12
HP253-4370	-	-	-	11.10	0.4370	55	102	12
HP253-4374	7/16	-	-	11.11	0.4374	55	102	12
HP253-4409	-	-	-	11.20	0.4409	55	102	12
HP253-4449	-	-	-	11.30	0.4449	55	102	12
HP253-4488	-	-	-	11.40	0.4488	55	102	12
HP253-4528	-	-	-	11.50	0.4528	55	102	12
HP253-4531	29/64	-	-	11.51	0.4531	55	102	12

Packed: 1 pc.
Available WD1 Coating Only.



List HP253

3D, Coolant-Through



EDP Number	Diameter					Flute Length FL	Overall Length L	Shank Diameter d
	Fractional Size	Wire Gage	Letter Size	mm	Inch			
HP253-4567	-	-	-	11.60	0.4567	55	102	12
HP253-4606	-	-	-	11.70	0.4606	55	102	12
HP253-4646	-	-	-	11.80	0.4646	55	102	12
HP253-4685	-	-	-	11.90	0.4685	55	102	12
HP253-4689	15/32	-	-	11.91	0.4689	55	102	12
HP253-4724	-	-	-	12.00	0.4724	55	102	12
HP253-4764	-	-	-	12.10	0.4764	60	107	14
HP253-4803	-	-	-	12.20	0.4803	60	107	14
HP253-4843	31/64	-	-	12.30	0.4843	60	107	14
HP253-4882	-	-	-	12.40	0.4882	60	107	14
HP253-4921	-	-	-	12.50	0.4921	60	107	14
HP253-4961	-	-	-	12.60	0.4961	60	107	14
HP253-5000	1/2	-	-	12.70	0.5000	60	107	14
HP253-5039	-	-	-	12.80	0.5039	60	107	14
HP253-5079	-	-	-	12.90	0.5079	60	107	14
HP253-5118	-	-	-	13.00	0.5118	60	107	14
HP253-5157	33/64	-	-	13.10	0.5157	60	107	14
HP253-5197	-	-	-	13.20	0.5197	60	107	14
HP253-5236	-	-	-	13.30	0.5236	60	107	14
HP253-5276	-	-	-	13.40	0.5276	60	107	14
HP253-5311	17/32	-	-	13.49	0.5311	60	107	14
HP253-5315	-	-	-	13.50	0.5315	60	107	14
HP253-5394	-	-	-	13.70	0.5394	60	107	14
HP253-5512	-	-	-	14.00	0.5512	60	107	14
HP253-5626	9/16	-	-	14.29	0.5626	65	115	16
HP253-5709	-	-	-	14.50	0.5709	65	115	16
HP253-5780	37/64	-	-	14.68	0.5780	65	115	16
HP253-5787	-	-	-	14.70	0.5787	65	115	16
HP253-5906	-	-	-	15.00	0.5906	65	115	16
HP253-5937	19/32	-	-	15.08	0.5937	65	115	15
HP253-6102	-	-	-	15.50	0.6102	65	115	16
HP253-6181	-	-	-	15.70	0.6181	65	115	16
HP253-6248	5/8	-	-	15.87	0.6248	65	115	16
HP253-6299	-	-	-	16.00	0.6299	65	115	16
HP253-6339	-	-	-	16.10	0.6339	73	123	18
HP253-6496	-	-	-	16.50	0.6496	73	123	18
HP253-6563	21/32	-	-	16.67	0.6563	73	123	18
HP253-6693	-	-	-	17.00	0.6693	73	123	18
HP253-6890	-	-	-	17.50	0.6890	73	123	18
HP253-7087	-	-	-	18.00	0.7087	73	123	18
HP253-7283	-	-	-	18.50	0.7283	79	131	20
HP253-7480	-	-	-	19.00	0.7480	79	131	20
HP253-7500	3/4	-	-	19.05	0.7500	79	131	20
HP253-7579	-	-	-	19.25	0.7579	79	131	20
HP253-7677	-	-	-	19.50	0.7677	79	131	20
HP253-7874	-	-	-	20.00	0.7874	79	131	20

Packed: 1 pc.
Available WD1 Coating Only.



Work Material																	
List No.	P					M			K	N		S		H			
	Carbon Steels			Alloy Steels	Die Steels	Stainless Steels			Cast Iron	Aluminum		Nickel Alloy	Titanium	Hardened Steels			
	Low	Med.	High	4140 4340	400	300	400	17-4 PH		6061 7075	Casting	Inconel	6Al4V (30 HRC)	~35 HRC	35-45 HRC	45-50 HRC	50-70 HRC
HP253	☐	☐	☐	☐	☐	☐	☐	☐	☐	☐	☐	☐	☐	☐	☐	☐	☐

☐ good ☐ best



List HP255

5D, Coolant-Through



SPEED FEED P23	CARBIDE	WD1		30°	SHANK h6
--------------------------	----------------	------------	--	------------	--------------------

Cutting Diameter Tolerance (m7)		
Size	mm	inch
D=3	+0.002 / +0.012	+0.0001 / +0.0005
3<D≤6	+0.004 / +0.016	+0.0002 / +0.0006
6<D≤10	+0.006 / +0.021	+0.0002 / +0.0008
10<D≤18	+0.007 / +0.025	+0.0003 / +0.0010
18<D≤20	+0.008 / +0.029	+0.0003 / +0.0011

EDP Number	Diameter					Flute Length FL	Overall Length L	Shank Diameter d
	Fractional Size	Wire Gage	Letter Size	mm	Inch			
HP255-1181	-	-	-	3.00	0.1181	28	66	6
HP255-1220	-	-	-	3.10	0.1220	28	66	6
HP255-1248	1/8	-	-	3.17	0.1248	28	66	6
HP255-1260	-	-	-	3.20	0.1260	28	66	6
HP255-1299	-	-	-	3.30	0.1299	28	66	6
HP255-1339	-	-	-	3.40	0.1339	28	66	6
HP255-1378	-	-	-	3.50	0.1378	28	66	6
HP255-1406	9/64	-	-	3.57	0.1406	28	66	6
HP255-1417	-	-	-	3.60	0.1417	28	66	6
HP255-1457	-	-	-	3.70	0.1457	28	66	6
HP255-1496	-	25	-	3.80	0.1496	36	74	6
HP255-1535	-	-	-	3.90	0.1535	36	74	6
HP255-1563	5/32	-	-	3.97	0.1563	36	74	6
HP255-1575	-	-	-	4.00	0.1575	36	74	6
HP255-1610	-	20	-	4.09	0.1610	36	74	6
HP255-1614	-	-	-	4.10	0.1614	36	74	6
HP255-1654	-	-	-	4.20	0.1654	36	74	6
HP255-1693	-	-	-	4.30	0.1693	36	74	6
HP255-1720	11/64	-	-	4.37	0.1720	36	74	6
HP255-1732	-	-	-	4.40	0.1732	36	74	6
HP255-1772	-	16	-	4.50	0.1772	36	74	6
HP255-1811	-	-	-	4.60	0.1811	36	74	6
HP255-1831	-	-	-	4.65	0.1831	36	74	6
HP255-1850	-	13	-	4.70	0.1850	36	74	6
HP255-1874	3/16	-	-	4.76	0.1874	44	82	6
HP255-1890	-	12	-	4.80	0.1890	44	82	6
HP255-1929	-	-	-	4.90	0.1929	44	82	6
HP255-1969	-	-	-	5.00	0.1969	44	82	6
HP255-2008	-	-	-	5.10	0.2008	44	82	6
HP255-2031	13/64	-	-	5.16	0.2031	44	82	6
HP255-2047	-	-	-	5.20	0.2047	44	82	6
HP255-2087	-	-	-	5.30	0.2087	44	82	6
HP255-2126	-	-	-	5.40	0.2126	44	82	6
HP255-2130	-	3	-	5.41	0.2130	44	82	6
HP255-2165	-	-	-	5.50	0.2165	44	82	6
HP255-2189	7/32	-	-	5.56	0.2189	44	82	6
HP255-2205	-	-	-	5.60	0.2205	44	82	6
HP255-2244	-	-	-	5.70	0.2244	44	82	6
HP255-2283	-	-	-	5.80	0.2283	44	82	6
HP255-2323	-	-	-	5.90	0.2323	44	82	6
HP255-2343	15/64	-	-	5.95	0.2343	44	82	6
HP255-2362	-	-	-	6.00	0.2362	44	82	6
HP255-2402	-	-	-	6.10	0.2402	53	91	8
HP255-2441	-	-	-	6.20	0.2441	53	91	8
HP255-2480	-	-	-	6.30	0.2480	53	91	8
HP255-2500	1/4	-	E	6.35	0.2500	53	91	8
HP255-2520	-	-	-	6.40	0.2520	53	91	8
HP255-2559	-	-	-	6.50	0.2559	53	91	8
HP255-2571	-	-	F	6.53	0.2571	53	91	8
HP255-2598	-	-	-	6.60	0.2598	53	91	8
HP255-2638	-	-	-	6.70	0.2638	53	91	8
HP255-2657	17/64	-	-	6.75	0.2657	53	91	8
HP255-2677	-	-	-	6.80	0.2677	53	91	8
HP255-2717	-	-	I	6.90	0.2717	53	91	8
HP255-2756	-	-	-	7.00	0.2756	53	91	8
HP255-2795	-	-	-	7.10	0.2795	53	91	8
HP255-2811	9/32	-	-	7.14	0.2811	53	91	8
HP255-2835	-	-	-	7.20	0.2835	53	91	8
HP255-2874	-	-	-	7.30	0.2874	53	91	8
HP255-2913	-	-	-	7.40	0.2913	53	91	8
HP255-2953	-	-	-	7.50	0.2953	53	91	8
HP255-2969	19/64	-	-	7.54	0.2969	53	91	8

Packed: 1 pc.
Available WD1 Coating Only.



List HP255

5D, Coolant-Through



EDP Number	Diameter					Flute Length FL	Overall Length L	Shank Diameter d
	Fractional Size	Wire Gage	Letter Size	mm	Inch			
HP255-2992	-	-	-	7.60	0.2992	53	91	8
HP255-3031	-	-	-	7.70	0.3031	53	91	8
HP255-3071	-	-	-	7.80	0.3071	53	91	8
HP255-3110	-	-	-	7.90	0.3110	53	91	8
HP255-3126	5/16	-	-	7.94	0.3126	53	91	8
HP255-3150	-	-	-	8.00	0.3150	53	91	8
HP255-3189	-	-	-	8.10	0.3189	61	103	10
HP255-3228	-	-	P	8.20	0.3228	61	103	10
HP255-3268	-	-	-	8.30	0.3268	61	103	10
HP255-3280	21/64	-	-	8.33	0.3280	61	103	10
HP255-3307	-	-	-	8.40	0.3307	61	103	10
HP255-3319	-	-	Q	8.43	0.3319	61	103	10
HP255-3346	-	-	-	8.50	0.3346	61	103	10
HP255-3386	-	-	-	8.60	0.3386	61	103	10
HP255-3425	-	-	-	8.70	0.3425	61	103	10
HP255-3437	11/32	-	-	8.73	0.3437	61	103	10
HP255-3465	-	-	-	8.80	0.3465	61	103	10
HP255-3504	-	-	-	8.90	0.3504	61	103	10
HP255-3543	-	-	-	9.00	0.3543	61	103	10
HP255-3583	-	-	-	9.10	0.3583	61	103	10
HP255-3594	23/64	-	-	9.13	0.3594	61	103	10
HP255-3622	-	-	-	9.20	0.3622	61	103	10
HP255-3642	-	-	-	9.25	0.3642	61	103	10
HP255-3661	-	-	-	9.30	0.3661	61	103	10
HP255-3701	-	-	-	9.40	0.3701	61	103	10
HP255-3740	-	-	-	9.50	0.3740	61	103	10
HP255-3748	3/8	-	-	9.52	0.3748	61	103	10
HP255-3780	-	-	-	9.60	0.3780	61	103	10
HP255-3819	-	-	-	9.70	0.3819	61	103	10
HP255-3858	-	-	W	9.80	0.3858	61	103	10
HP255-3898	-	-	-	9.90	0.3898	61	103	10
HP255-3906	25/64	-	-	9.92	0.3906	61	103	10
HP255-3937	-	-	-	10.00	0.3937	61	103	10
HP255-3976	-	-	-	10.10	0.3976	71	118	12
HP255-4016	-	-	-	10.20	0.4016	71	118	12
HP255-4055	-	-	-	10.30	0.4055	71	118	12
HP255-4063	13/32	-	-	10.32	0.4063	71	118	12
HP255-4094	-	-	-	10.40	0.4094	71	118	12
HP255-4134	-	-	-	10.50	0.4134	71	118	12
HP255-4173	-	-	-	10.60	0.4173	71	118	12
HP255-4213	-	-	-	10.70	0.4213	71	118	12
HP255-4220	27/64	-	-	10.72	0.4220	71	118	12
HP255-4252	-	-	-	10.80	0.4252	71	118	12
HP255-4291	-	-	-	10.90	0.4291	71	118	12
HP255-4331	-	-	-	11.00	0.4331	71	118	12
HP255-4370	-	-	-	11.10	0.4370	71	118	12
HP255-4374	7/16	-	-	11.11	0.4374	71	118	12
HP255-4409	-	-	-	11.20	0.4409	71	118	12
HP255-4449	-	-	-	11.30	0.4449	71	118	12
HP255-4488	-	-	-	11.40	0.4488	71	118	12
HP255-4528	-	-	-	11.50	0.4528	71	118	12
HP255-4531	29/64	-	-	11.51	0.4531	71	118	12
HP255-4567	-	-	-	11.60	0.4567	71	118	12
HP255-4606	-	-	-	11.70	0.4606	71	118	12
HP255-4646	-	-	-	11.80	0.4646	71	118	12
HP255-4685	-	-	-	11.90	0.4685	71	118	12
HP255-4689	15/32	-	-	11.91	0.4689	71	118	12
HP255-4724	-	-	-	12.00	0.4724	71	118	12
HP255-4764	-	-	-	12.10	0.4764	77	124	14

Packed: 1 pc.
Available WD1 Coating Only.

continued on next page

Work Material																	
List No.	P					M			K	N		S		H			
	Carbon Steels			Alloy Steels 4140 4340	Die Steels 400	Stainless Steels			Cast Iron	Aluminum		Nickel Alloy Inconel	Titanium 6Al4V (30 HRC)	Hardened Steels			
	Low 1010 1018	Med. 1035 1045	High 1065			300	400	17-4 PH		6061 7075	Casting			~35 HRC	35-45 HRC	45-50 HRC	50-70 HRC
HP255	<input checked="" type="checkbox"/>	<input checked="" type="checkbox"/>	<input checked="" type="checkbox"/>	<input checked="" type="checkbox"/>	<input checked="" type="checkbox"/>	<input type="checkbox"/>	<input type="checkbox"/>	<input type="checkbox"/>	<input checked="" type="checkbox"/>	<input type="checkbox"/>	<input type="checkbox"/>	<input type="checkbox"/>	<input checked="" type="checkbox"/>	<input type="checkbox"/>	<input type="checkbox"/>	<input type="checkbox"/>	

good best



List HP255

5D, Coolant-Through



SPEED FEED P23	CARBIDE	WD1	30°	SHANK h6
--------------------------	----------------	------------	------------	--------------------

Cutting Diameter Tolerance (m7)		
Size	mm	inch
D=3	+0.002 / +0.012	+0.0001 / +0.0005
3<D≤6	+0.004 / +0.016	+0.0002 / +0.0006
6<D≤10	+0.006 / +0.021	+0.0002 / +0.0008
10<D≤18	+0.007 / +0.025	+0.0003 / +0.0010
18<D≤20	+0.008 / +0.029	+0.0003 / +0.0011

EDP Number	Diameter					Flute Length FL	Overall Length L	Shank Diameter d
	Fractional Size	Wire Gage	Letter Size	mm	Inch			
HP255-4803	-	-	-	12.20	0.4803	77	124	14
HP255-4843	31/64	-	-	12.30	0.4843	77	124	14
HP255-4882	-	-	-	12.40	0.4882	77	124	14
HP255-4921	-	-	-	12.50	0.4921	77	124	14
HP255-4961	-	-	-	12.60	0.4961	77	124	14
HP255-5000	1/2	-	-	12.70	0.5000	77	124	14
HP255-5039	-	-	-	12.80	0.5039	77	124	14
HP255-5079	-	-	-	12.90	0.5079	77	124	14
HP255-5118	-	-	-	13.00	0.5118	77	124	14
HP255-5157	33/64	-	-	13.10	0.5157	77	124	14
HP255-5197	-	-	-	13.20	0.5197	77	124	14
HP255-5236	-	-	-	13.30	0.5236	77	124	14
HP255-5276	-	-	-	13.40	0.5276	77	124	14
HP255-5311	17/32	-	-	13.49	0.5311	77	124	14
HP255-5315	-	-	-	13.50	0.5315	77	124	14
HP255-5394	-	-	-	13.70	0.5394	77	124	14
HP255-5512	-	-	-	14.00	0.5512	77	124	14
HP255-5626	9/16	-	-	14.29	0.5626	83	133	16
HP255-5709	-	-	-	14.50	0.5709	83	133	16
HP255-5780	37/64	-	-	14.68	0.5780	83	133	16
HP255-5787	-	-	-	14.70	0.5787	83	133	16
HP255-5906	-	-	-	15.00	0.5906	83	133	16
HP255-5937	19/32	-	-	15.08	0.5937	83	133	16
HP255-6102	-	-	-	15.50	0.6102	83	133	16
HP255-6181	-	-	-	15.70	0.6181	83	133	16
HP255-6248	5/8	-	-	15.87	0.6248	83	133	16
HP255-6299	-	-	-	16.00	0.6299	83	133	16
HP255-6339	-	-	-	16.10	0.6339	93	143	18
HP255-6496	-	-	-	16.50	0.6496	93	143	18
HP255-6563	21/32	-	-	16.67	0.6563	93	143	18
HP255-6693	-	-	-	17.00	0.6693	93	143	18
HP255-6890	-	-	-	17.50	0.6890	93	143	18
HP255-7087	-	-	-	18.00	0.7087	93	143	18
HP255-7283	-	-	-	18.50	0.7283	101	153	20
HP255-7480	-	-	-	19.00	0.7480	101	153	20
HP255-7500	3/4	-	-	19.05	0.7500	101	153	20
HP255-7579	-	-	-	19.25	0.7579	101	153	20
HP255-7677	-	-	-	19.50	0.7677	101	153	20
HP255-7874	-	-	-	20.00	0.7874	101	153	20

Packed: 1 pc.
Available WD1 Coating Only.



List No.	Work Material																	
	P						M			K	N		S		H			
	Carbon Steels			Alloy Steels	Die Steels	Stainless Steels			Cast Iron	Aluminum		Nickel Alloy	Titanium	Hardened Steels				
	Low	Med.	High			300	400	17-4 PH		6061	Casting			Inconel	6Al4V (30 HRC)	~35 HRC	35-45 HRC	45-50 HRC
HP255	<input checked="" type="checkbox"/>	<input checked="" type="checkbox"/>	<input checked="" type="checkbox"/>	<input checked="" type="checkbox"/>	<input checked="" type="checkbox"/>	<input type="checkbox"/>	<input type="checkbox"/>	<input type="checkbox"/>	<input checked="" type="checkbox"/>	<input type="checkbox"/>	<input type="checkbox"/>	<input type="checkbox"/>	<input type="checkbox"/>	<input checked="" type="checkbox"/>	<input type="checkbox"/>	<input type="checkbox"/>	<input type="checkbox"/>	

good best



List HP258

8D, Coolant-Through

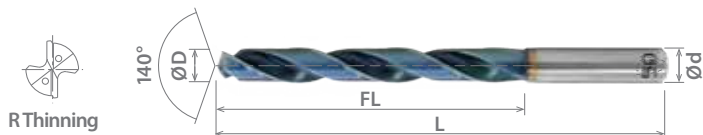

SPEED FEED P23	CARBIDE	WD1	30°	SHANK h6
--------------------------	----------------	------------	------------	--------------------

Cutting Diameter Tolerance (m7)		
Size	mm	inch
D=3	+0.002 / +0.012	+0.0001 / +0.0005
3<D≤6	+0.004 / +0.016	+0.0002 / +0.0006
6<D≤10	+0.006 / +0.021	+0.0002 / +0.0008
10<D≤18	+0.007 / +0.025	+0.0003 / +0.0010
18<D≤20	+0.008 / +0.029	+0.0003 / +0.0011

EDP Number	Diameter					Flute Length FL	Overall Length L	Shank Diameter d
	Fractional Size	Wire Gage	Letter Size	mm	Inch			
HP258-1181	-	-	-	3.00	0.1181	34	77	4
HP258-1220	-	-	-	3.10	0.1220	36	77	4
HP258-1248	1/8	-	-	3.17	0.1248	36	77	4
HP258-1260	-	-	-	3.20	0.1260	36	77	4
HP258-1299	-	-	-	3.30	0.1299	36	77	4
HP258-1339	-	-	-	3.40	0.1339	36	77	4
HP258-1378	-	-	-	3.50	0.1378	36	77	4
HP258-1406	9/64	-	-	3.57	0.1406	36	77	4
HP258-1417	-	-	-	3.60	0.1417	36	77	4
HP258-1457	-	-	-	3.70	0.1457	36	77	4
HP258-1496	-	25	-	3.80	0.1496	45	85	4
HP258-1535	-	-	-	3.90	0.1535	45	85	4
HP258-1563	5/32	-	-	3.97	0.1563	45	85	4
HP258-1575	-	-	-	4.00	0.1575	45	85	4
HP258-1610	-	20	-	4.09	0.1610	45	85	6
HP258-1614	-	-	-	4.10	0.1614	45	85	6
HP258-1654	-	-	-	4.20	0.1654	45	85	6
HP258-1693	-	-	-	4.30	0.1693	45	85	6
HP258-1720	11/64	-	-	4.37	0.1720	45	85	6
HP258-1732	-	-	-	4.40	0.1732	45	85	6
HP258-1772	-	16	-	4.50	0.1772	45	85	6
HP258-1811	-	-	-	4.60	0.1811	45	85	6
HP258-1831	-	-	-	4.65	0.1831	45	85	6
HP258-1850	-	13	-	4.70	0.1850	45	85	6
HP258-1874	3/16	-	-	4.76	0.1874	50	90	6
HP258-1890	-	-	-	4.80	0.1890	50	90	6
HP258-1929	-	-	-	4.90	0.1929	50	90	6
HP258-1969	-	-	-	5.00	0.1969	50	90	6
HP258-2008	-	-	-	5.10	0.2008	57	97	6
HP258-2031	13/64	-	-	5.16	0.2031	57	97	6
HP258-2047	-	-	-	5.20	0.2047	57	97	6
HP258-2087	-	-	-	5.30	0.2087	57	97	6
HP258-2126	-	-	-	5.40	0.2126	57	97	6
HP258-2130	-	3	-	5.41	0.2130	57	97	6
HP258-2165	-	-	-	5.50	0.2165	57	97	6
HP258-2189	7/32	-	-	5.56	0.2189	57	97	6
HP258-2205	-	-	-	5.60	0.2205	57	97	6
HP258-2244	-	-	-	5.70	0.2244	57	97	6
HP258-2283	-	-	-	5.80	0.2283	57	97	6
HP258-2323	-	-	-	5.90	0.2323	57	97	6
HP258-2343	15/64	-	-	5.95	0.2343	57	97	6
HP258-2362	-	-	-	6.00	0.2362	57	97	6
HP258-2402	-	-	-	6.10	0.2402	66	106	8
HP258-2441	-	-	-	6.20	0.2441	66	106	8
HP258-2480	-	-	-	6.30	0.2480	66	106	8
HP258-2500	1/4	-	E	6.35	0.2500	66	106	8
HP258-2520	-	-	-	6.40	0.2520	66	106	8
HP258-2559	-	-	-	6.50	0.2559	66	106	8
HP258-2571	-	-	F	6.53	0.2571	66	106	8
HP258-2598	-	-	-	6.60	0.2598	66	106	8
HP258-2638	-	-	-	6.70	0.2638	66	106	8
HP258-2657	17/64	-	-	6.75	0.2657	66	106	8

Packed: 1 pc.
Available WD1 Coating Only.

continued on next page

List No.	Work Material																
	P					M			K	N		S		H			
	Carbon Steels			Alloy Steels	Die Steels	Stainless Steels			Cast Iron	Aluminum		Nickel Alloy	Titanium	Hardened Steels			
Low	Med.	High	4140 4340	400	300	400	17-4 PH	6061 7075		Casting	Inconel	6Al4V (30 HRC)	~35 HRC	35-45 HRC	45-50 HRC	50-70 HRC	
HP258	<input checked="" type="checkbox"/>	<input checked="" type="checkbox"/>	<input checked="" type="checkbox"/>	<input checked="" type="checkbox"/>	<input checked="" type="checkbox"/>	<input type="checkbox"/>	<input type="checkbox"/>	<input type="checkbox"/>	<input checked="" type="checkbox"/>	<input type="checkbox"/>	<input type="checkbox"/>	<input type="checkbox"/>	<input checked="" type="checkbox"/>	<input type="checkbox"/>	<input type="checkbox"/>	<input type="checkbox"/>	

good best



List HP258

8D, Coolant-Through



SPEED FEED P23	CARBIDE	WD1		30°	SHANK h6
--------------------------	----------------	------------	--	------------	--------------------

Cutting Diameter Tolerance (m7)		
Size	mm	inch
D=3	+0.002 / +0.012	+0.0001 / +0.0005
3<D≤6	+0.004 / +0.016	+0.0002 / +0.0006
6<D≤10	+0.006 / +0.021	+0.0002 / +0.0008
10<D≤18	+0.007 / +0.025	+0.0003 / +0.0010
18<D≤20	+0.008 / +0.029	+0.0003 / +0.0011

EDP Number	Diameter					Flute Length FL	Overall Length L	Shank Diameter d
	Fractional Size	Wire Gage	Letter Size	mm	Inch			
HP258-2677	-	-	-	6.80	0.2677	66	106	8
HP258-2717	-	-	I	6.90	0.2717	76	116	8
HP258-2756	-	-	-	7.00	0.2756	76	116	8
HP258-2795	-	-	-	7.10	0.2795	76	116	8
HP258-2811	9/32	-	-	7.14	0.2811	76	116	8
HP258-2835	-	-	-	7.20	0.2835	76	116	8
HP258-2874	-	-	-	7.30	0.2874	76	116	8
HP258-2913	-	-	-	7.40	0.2913	76	116	8
HP258-2953	-	-	-	7.50	0.2953	76	116	8
HP258-2969	19/64	-	-	7.54	0.2969	76	116	8
HP258-2992	-	-	-	7.60	0.2992	76	116	8
HP258-3031	-	-	-	7.70	0.3031	76	116	8
HP258-3071	-	-	-	7.80	0.3071	76	116	8
HP258-3110	-	-	-	7.90	0.3110	76	116	8
HP258-3126	5/16	-	-	7.94	0.3126	76	116	8
HP258-3150	-	-	-	8.00	0.3150	76	116	8
HP258-3189	-	-	-	8.10	0.3189	87	131	10
HP258-3228	-	-	P	8.20	0.3228	87	131	10
HP258-3268	-	-	-	8.30	0.3268	87	131	10
HP258-3280	21/64	-	-	8.33	0.3280	87	131	10
HP258-3307	-	-	-	8.40	0.3307	87	131	10
HP258-3319	-	-	Q	8.43	0.3319	87	131	10
HP258-3346	-	-	-	8.50	0.3346	87	131	10
HP258-3386	-	-	-	8.60	0.3386	87	131	10
HP258-3425	-	-	-	8.70	0.3425	87	131	10
HP258-3437	11/32	-	-	8.73	0.3437	87	131	10
HP258-3465	-	-	-	8.80	0.3465	87	131	10
HP258-3504	-	-	-	8.90	0.3504	87	131	10
HP258-3543	-	-	-	9.00	0.3543	87	131	10
HP258-3583	-	-	-	9.10	0.3583	95	139	10
HP258-3594	23/64	-	-	9.13	0.3594	95	139	10
HP258-3622	-	-	-	9.20	0.3622	95	139	10
HP258-3642	-	-	-	9.25	0.3642	95	139	10
HP258-3661	-	-	-	9.30	0.3661	95	139	10
HP258-3701	-	-	-	9.40	0.3701	95	139	10
HP258-3740	-	-	-	9.50	0.3740	95	139	10
HP258-3748	3/8	-	-	9.52	0.3748	95	139	10
HP258-3780	-	-	-	9.60	0.3780	95	139	10
HP258-3819	-	-	-	9.70	0.3819	95	139	10
HP258-3858	-	-	W	9.80	0.3858	95	139	10
HP258-3898	-	-	-	9.90	0.3898	95	139	10
HP258-3906	25/64	-	-	9.92	0.3906	95	139	10
HP258-3937	-	-	-	10.00	0.3937	95	139	10
HP258-3976	-	-	-	10.10	0.3976	106	155	12
HP258-4016	-	-	-	10.20	0.4016	106	155	12
HP258-4055	-	-	-	10.30	0.4055	106	155	12
HP258-4063	13/32	-	-	10.32	0.4063	106	155	12
HP258-4094	-	-	-	10.40	0.4094	106	155	12
HP258-4134	-	-	-	10.50	0.4134	106	155	12
HP258-4173	-	-	-	10.60	0.4173	106	155	12
HP258-4213	-	-	-	10.70	0.4213	106	155	12
HP258-4220	27/64	-	-	10.72	0.4220	106	155	12
HP258-4252	-	-	-	10.80	0.4252	106	155	12
HP258-4291	-	-	-	10.90	0.4291	106	155	12
HP258-4331	-	-	-	11.00	0.4331	106	155	12
HP258-4370	-	-	-	11.10	0.4370	114	163	12
HP258-4374	7/16	-	-	11.11	0.4374	114	163	12
HP258-4409	-	-	-	11.20	0.4409	114	163	12
HP258-4449	-	-	-	11.30	0.4449	114	163	12
HP258-4488	-	-	-	11.40	0.4488	114	163	12
HP258-4528	-	-	-	11.50	0.4528	114	163	12
HP258-4531	29/64	-	-	11.51	0.4531	114	163	12

Packed: 1 pc.
Available WD1 Coating Only.



List HP258

8D, Coolant-Through



EDP Number	Diameter					Flute Length FL	Overall Length L	Shank Diameter d
	Fractional Size	Wire Gage	Letter Size	mm	Inch			
HP258-4567	-	-	-	11.60	0.4567	114	163	12
HP258-4606	-	-	-	11.70	0.4606	114	163	12
HP258-4646	-	-	-	11.80	0.4646	114	163	12
HP258-4685	-	-	-	11.90	0.4685	114	163	12
HP258-4689	15/32	-	-	11.91	0.4689	114	163	12
HP258-4724	-	-	-	12.00	0.4724	114	163	12
HP258-4764	-	-	-	12.10	0.4764	133	182	14
HP258-4803	-	-	-	12.20	0.4803	133	182	14
HP258-4843	31/64	-	-	12.30	0.4843	133	182	14
HP258-4882	-	-	-	12.40	0.4882	133	182	14
HP258-4921	-	-	-	12.50	0.4921	133	182	14
HP258-4961	-	-	-	12.60	0.4961	133	182	14
HP258-5000	1/2	-	-	12.70	0.5000	133	182	14
HP258-5039	-	-	-	12.80	0.5039	133	182	14
HP258-5079	-	-	-	12.90	0.5079	133	182	14
HP258-5118	-	-	-	13.00	0.5118	133	182	14
HP258-5157	33/64	-	-	13.10	0.5157	133	182	14
HP258-5197	-	-	-	13.20	0.5197	133	182	14
HP258-5236	-	-	-	13.30	0.5236	133	182	14
HP258-5276	-	-	-	13.40	0.5276	133	182	14
HP258-5311	17/32	-	-	13.49	0.5311	133	182	14
HP258-5315	-	-	-	13.50	0.5315	133	182	14
HP258-5394	-	-	-	13.70	0.5394	133	182	14
HP258-5512	-	-	-	14.00	0.5512	133	182	14
HP258-5626	9/16	-	-	14.29	0.5626	152	204	16
HP258-5709	-	-	-	14.50	0.5709	152	204	16
HP258-5780	37/64	-	-	14.68	0.5780	152	204	16
HP258-5787	-	-	-	14.70	0.5787	152	204	16
HP258-5906	-	-	-	15.00	0.5906	152	204	16
HP258-5937	19/32	-	-	15.08	0.5937	152	204	16
HP258-6102	-	-	-	15.50	0.6102	152	204	16
HP258-6181	-	-	-	15.70	0.6181	152	204	16
HP258-6248	5/8	-	-	15.87	0.6248	152	204	16
HP258-6299	-	-	-	16.00	0.6299	152	204	16
HP258-6496	-	-	-	16.50	0.6496	171	223	18
HP258-6563	21/32	-	-	16.67	0.6563	171	223	18
HP258-6693	-	-	-	17.00	0.6693	171	223	18
HP258-6890	-	-	-	17.50	0.6890	171	223	18
HP258-7087	-	-	-	18.00	0.7087	171	223	18
HP258-7283	-	-	-	18.50	0.7283	190	244	20
HP258-7480	-	-	-	19.00	0.7480	190	244	20
HP258-7500	3/4	-	-	19.05	0.7500	190	244	20
HP258-7677	-	-	-	19.50	0.7677	190	244	20
HP258-7874	-	-	-	20.00	0.7874	190	244	20

Packed: 1 pc.
Available WD1 Coating Only.



Work Material																	
List No.	P					M			K	N		S		H			
	Carbon Steels			Alloy Steels	Die Steels	Stainless Steels			Cast Iron	Aluminum		Nickel Alloy	Titanium	Hardened Steels			
	Low 1010 1018	Med. 1035 1045	High 1065	4140 4340	400	300	400	17-4 PH		6061 7075	Casting	Inconel	6Al4V (30 HRC)	~35 HRC	35-45 HRC	45-50 HRC	50-70 HRC
HP258	☐	☐	☐	☐	☐	☐	☐	☐	☐	☐	☐	☐	☐	☐	☐	☐	

☐ good ☐ best



List HP243 - HY-PRO® CARB: 3D List HP245 - HY-PRO® CARB: 5D

General Drilling Operations

Work Material		Carbon Steels, Mild Steel 1010, 1050, 12L14		Alloy Steels 4140, 4130		Cast Iron		Ductile Cast Iron		Aluminum Alloy	
Drilling Speed		240-350 SFM		230-325 SFM		240-385 SFM		175-300 SFM		200-380 SFM	
Drill Dia.		Speed RPM	Feed IPR	Speed RPM	Feed IPR	Speed RPM	Feed IPR	Speed RPM	Feed IPR	Speed RPM	Feed IPR
mm	Inch										
1	-	28,620	0.001 - 0.002	26,870	0.001 - 0.002	30,270	0.001 - 0.002	23,090	0.001 - 0.002	26,170	0.001 - 0.002
-	1/16	18,030	0.001 - 0.002	16,930	0.001 - 0.002	19,620	0.001 - 0.002	14,550	0.001 - 0.002	16,500	0.001 - 0.002
2	-	14,310	0.002 - 0.003	13,430	0.001 - 0.003	15,130	0.001 - 0.003	11,540	0.001 - 0.003	13,100	0.002 - 0.003
-	3/32	12,020	0.002 - 0.004	11,280	0.002 - 0.004	13,080	0.002 - 0.004	9,700	0.002 - 0.004	11,000	0.002 - 0.004
3	-	9,540	0.002 - 0.005	8,960	0.002 - 0.005	10,090	0.002 - 0.005	7,700	0.002 - 0.005	9,700	0.003 - 0.005
-	1/8	9,010	0.003 - 0.005	8,460	0.003 - 0.005	9,810	0.002 - 0.005	7,270	0.003 - 0.005	9,060	0.004 - 0.005
4	-	7,160	0.003 - 0.006	6,720	0.003 - 0.006	7,560	0.003 - 0.006	5,770	0.003 - 0.006	7,270	0.004 - 0.006
-	3/16	6,010	0.004 - 0.008	5,640	0.004 - 0.008	6,540	0.004 - 0.007	4,850	0.004 - 0.007	6,110	0.005 - 0.007
6	-	4,770	0.005 - 0.009	4,480	0.005 - 0.009	5,040	0.005 - 0.009	3,850	0.005 - 0.009	4,850	0.006 - 0.008
-	1/4	4,510	0.005 - 0.010	4,230	0.005 - 0.010	4,910	0.005 - 0.010	3,640	0.005 - 0.010	4,580	0.007 - 0.009
8	-	3,580	0.006 - 0.011	3,360	0.006 - 0.011	3,780	0.006 - 0.011	2,890	0.006 - 0.011	3,640	0.008 - 0.010
-	3/8	3,010	0.007 - 0.011	2,820	0.007 - 0.011	3,270	0.007 - 0.011	2,020	0.007 - 0.011	3,050	0.009 - 0.011
10	-	2,860	0.008 - 0.012	2,680	0.008 - 0.012	3,030	0.008 - 0.012	2,310	0.008 - 0.012	2,910	0.011 - 0.013
-	7/16	2,580	0.008 - 0.012	2,420	0.008 - 0.012	2,800	0.008 - 0.012	2,080	0.008 - 0.012	2,620	0.012 - 0.014
12	-	2,380	0.008 - 0.012	2,240	0.008 - 0.012	2,520	0.008 - 0.012	1,920	0.008 - 0.012	2,420	0.013 - 0.015
-	1/2	2,250	0.009 - 0.013	2,120	0.009 - 0.013	2,450	0.008 - 0.013	1,820	0.008 - 0.013	2,290	0.014 - 0.016
14	-	2,040	0.009 - 0.014	1,920	0.009 - 0.014	2,160	0.009 - 0.014	1,650	0.009 - 0.014	2,080	0.016 - 0.018
-	5/8	1,810	0.010 - 0.014	1,690	0.010 - 0.014	1,960	0.010 - 0.014	1,450	0.010 - 0.014	1,830	0.018 - 0.020
18	-	1,590	0.011 - 0.015	1,490	0.011 - 0.015	1,682	0.011 - 0.015	1,280	0.011 - 0.015	1,620	0.020 - 0.022
-	3/4	1,500	0.012 - 0.015	1,410	0.012 - 0.015	1,580	0.011 - 0.015	1,210	0.012 - 0.015	1,520	0.021 - 0.023
20	-	1,430	0.012 - 0.016	1,340	0.012 - 0.016	1,514	0.012 - 0.016	1,150	0.012 - 0.016	1,450	0.022 - 0.024

General Drilling Operations

Work Material		Cast Aluminum		Copper		Special Alloy Steels, Hardened Steels							
Drilling Speed		260- 640 SFM		190-320 SFM		26-30 HRC		30-34 HRC		34-43 HRC		43-48 HRC	
Drill Dia.		Speed RPM	Feed IPR	Speed RPM	Feed IPR	Speed RPM	Feed IPR	Speed RPM	Feed IPR	Speed RPM	Feed IPR	Speed RPM	Feed IPR
mm	Inch												
1	-	31,990	0.002 - 0.003	24,740	0.001 - 0.002	19,400	0.001 - 0.002	14,260	0.001 - 0.002	12,130	0.001 - 0.001	8,440	0.0005 - 0.001
-	1/16	20,170	0.002 - 0.003	15,580	0.001 - 0.002	12,220	0.001 - 0.002	8,980	0.001 - 0.002	7,640	0.001 - 0.002	5,320	0.0005 - 0.001
2	-	18,020	0.003 - 0.004	12,370	0.002 - 0.003	9,700	0.001 - 0.003	7,130	0.001 - 0.003	6,060	0.001 - 0.002	4,220	0.001 - 0.001
-	3/32	15,160	0.004 - 0.005	10,390	0.002 - 0.004	8,150	0.002 - 0.004	5,990	0.002 - 0.003	5,090	0.002 - 0.003	3,540	0.001 - 0.002
3	-	14,550	0.004 - 0.006	8,250	0.003 - 0.005	6,470	0.002 - 0.005	4,750	0.002 - 0.003	4,040	0.002 - 0.003	2,810	0.001 - 0.002
-	1/8	13,750	0.005 - 0.006	7,790	0.003 - 0.005	6,110	0.003 - 0.005	4,490	0.003 - 0.004	3,820	0.003 - 0.004	2,660	0.002 - 0.003
4	-	10,920	0.005 - 0.007	6,180	0.004 - 0.006	4,850	0.003 - 0.006	3,560	0.003 - 0.004	3,030	0.003 - 0.004	2,110	0.002 - 0.003
-	3/16	9,170	0.006 - 0.008	5,190	0.005 - 0.007	4,070	0.004 - 0.008	2,990	0.004 - 0.005	2,550	0.004 - 0.005	1,770	0.002 - 0.003
6	-	7,270	0.008 - 0.010	4,120	0.006 - 0.008	3,230	0.005 - 0.009	2,380	0.005 - 0.006	2,020	0.005 - 0.006	1,410	0.002 - 0.004
-	1/4	6,870	0.010 - 0.012	3,890	0.007 - 0.009	3,050	0.005 - 0.010	2,240	0.006 - 0.007	1,910	0.006 - 0.007	1,330	0.002 - 0.004
8	-	5,460	0.012 - 0.014	3,090	0.008 - 0.010	2,420	0.006 - 0.011	1,780	0.006 - 0.008	1,520	0.006 - 0.008	1,050	0.003 - 0.005
-	3/8	4,580	0.013 - 0.015	2,590	0.009 - 0.011	2,040	0.007 - 0.011	1,490	0.007 - 0.009	1,270	0.007 - 0.009	880	0.003 - 0.005
10	-	4,360	0.015 - 0.017	2,470	0.011 - 0.013	1,940	0.008 - 0.012	1,420	0.008 - 0.010	1,210	0.008 - 0.010	840	0.004 - 0.006
-	7/16	3,930	0.016 - 0.018	2,220	0.012 - 0.014	1,740	0.008 - 0.012	1,280	0.008 - 0.011	1,090	0.009 - 0.011	760	0.004 - 0.006
12	-	3,640	0.018 - 0.020	2,060	0.013 - 0.015	1,620	0.008 - 0.012	1,190	0.009 - 0.012	1,010	0.009 - 0.012	700	0.005 - 0.007
-	1/2	3,440	0.019 - 0.021	1,450	0.014 - 0.016	1,530	0.009 - 0.013	1,120	0.010 - 0.013	950	0.010 - 0.013	660	0.005 - 0.007
14	-	3,120	0.021 - 0.023	1,770	0.016 - 0.018	1,390	0.009 - 0.014	1,020	0.011 - 0.014	860	0.011 - 0.014	600	0.006 - 0.008
-	5/8	2,750	0.022 - 0.026	1,560	0.018 - 0.020	1,220	0.010 - 0.014	900	0.012 - 0.016	760	0.013 - 0.016	530	0.006 - 0.008
18	-	2,420	0.026 - 0.030	1,370	0.020 - 0.022	1,080	0.011 - 0.015	790	0.014 - 0.018	670	0.015 - 0.018	470	0.007 - 0.009
-	3/4	2,290	0.027 - 0.031	1,300	0.021 - 0.023	1,020	0.012 - 0.015	750	0.015 - 0.019	640	0.016 - 0.019	440	0.008 - 0.010
20	-	2,180	0.028 - 0.032	1,240	0.022 - 0.024	970	0.012 - 0.016	710	0.016 - 0.020	610	0.016 - 0.020	420	0.008 - 0.011



List HP253 - HY-PRO® CARB: 3D Coolant-Through

List HP255 - HY-PRO® CARB: 5D Coolant-Through

List HP258 - HY-PRO® CARB: 5D Coolant-Through

General Drilling Operations

Work Material	Carbon Steels, Mild Steel 1010, 1050, 12L14		Alloy Steels 4140, 4130		Stainless Steels 300SS, 400SS, 17-4PH		Cast Iron		Ductile Cast Iron		Aluminum Alloy		
Drilling Speed	310-455 SFM		265-380 SFM		145-220 SFM		285-420 SFM		215-350 SFM		260-450 SFM		
Drill Dia.	Speed RPM	Feed IPR	Speed RPM	Feed IPR	Speed RPM	Feed IPR	Speed RPM	Feed IPR	Speed RPM	Feed IPR	Speed RPM	Feed IPR	
mm	Inch												
3	-	11,450	0.002 - 0.005	10,750	0.002 - 0.005	6,140	0.002 - 0.004	12,610	0.002 - 0.005	9,630	0.002 - 0.005	13,100	0.003 - 0.005
-	1/8	10,810	0.002 - 0.005	10,170	0.002 - 0.005	5,810	0.002 - 0.004	11,850	0.002 - 0.005	9,110	0.002 - 0.005	12,370	0.003 - 0.005
4	-	8,580	0.003 - 0.006	8,060	0.003 - 0.006	4,600	0.003 - 0.005	9,460	0.003 - 0.006	7,210	0.003 - 0.006	9,820	0.004 - 0.006
-	3/16	7,200	0.004 - 0.007	6,780	0.004 - 0.007	3,870	0.004 - 0.006	7,900	0.004 - 0.007	6,070	0.004 - 0.007	8,250	0.005 - 0.007
6	-	5,725	0.005 - 0.009	5,370	0.005 - 0.009	3,070	0.005 - 0.007	6,300	0.005 - 0.009	4,810	0.005 - 0.009	6,550	0.006 - 0.008
-	1/4	5,410	0.005 - 0.010	5,090	0.005 - 0.010	2,900	0.006 - 0.008	5,920	0.005 - 0.010	4,550	0.005 - 0.010	6,190	0.007 - 0.009
8	-	4,290	0.006 - 0.011	4,040	0.006 - 0.011	2,300	0.006 - 0.009	4,730	0.006 - 0.011	3,610	0.006 - 0.011	4,910	0.008 - 0.010
-	3/8	3,600	0.007 - 0.011	3,390	0.007 - 0.011	1,930	0.007 - 0.009	3,950	0.007 - 0.011	3,030	0.007 - 0.011	4,120	0.009 - 0.011
10	-	3,430	0.008 - 0.012	3,230	0.008 - 0.012	1,840	0.008 - 0.010	3,780	0.008 - 0.012	2,890	0.008 - 0.012	3,930	0.011 - 0.013
-	7/16	3,090	0.008 - 0.012	2,910	0.008 - 0.012	1,660	0.008 - 0.010	3,380	0.008 - 0.012	2,600	0.008 - 0.012	3,530	0.012 - 0.014
12	-	2,860	0.008 - 0.012	2,690	0.008 - 0.012	1,530	0.008 - 0.010	3,150	0.008 - 0.012	2,410	0.008 - 0.012	3,280	0.013 - 0.015
-	1/2	2,700	0.008 - 0.013	2,540	0.008 - 0.013	1,450	0.008 - 0.010	2,960	0.008 - 0.013	2,270	0.008 - 0.013	3,090	0.014 - 0.016
14	-	2,450	0.009 - 0.014	2,310	0.009 - 0.014	1,310	0.009 - 0.011	2,690	0.009 - 0.014	2,060	0.009 - 0.014	2,810	0.016 - 0.018
-	5/8	2,160	0.010 - 0.014	2,030	0.010 - 0.014	1,160	0.010 - 0.012	2,370	0.010 - 0.014	1,820	0.010 - 0.014	2,470	0.018 - 0.020
18	-	1,910	0.011 - 0.015	1,790	0.011 - 0.015	1,020	0.011 - 0.013	2,090	0.011 - 0.015	1,610	0.011 - 0.015	2,180	0.020 - 0.022
-	3/4	1,800	0.011 - 0.015	1,690	0.011 - 0.015	960	0.011 - 0.013	1,970	0.011 - 0.015	1,520	0.011 - 0.015	2,060	0.021 - 0.023
20	-	1,720	0.012 - 0.016	1,610	0.012 - 0.016	922	0.012 - 0.014	1,880	0.012 - 0.016	1,450	0.012 - 0.016	1,960	0.022 - 0.024

General Drilling Operations

Work Material	Cast Aluminum	Copper	Special Alloy Steels, Hardened Steels										
			26-30 HRC		30-34 HRC		34-43 HRC		43-48 HRC				
Drilling Speed	325- 700 SFM		230-380 SFM		185-295 SFM		130-210 SFM		120-180 SFM		80-110 SFM		
Drill Dia.	Speed RPM	Feed IPR	Speed RPM	Feed IPR	Speed RPM	Feed IPR	Speed RPM	Feed IPR	Speed RPM	Feed IPR	Speed RPM	Feed IPR	
mm	Inch												
3	-	19,650	0.004 - 0.006	10,110	0.003 - 0.005	7,760	0.002 - 0.005	5,700	0.002 - 0.003	4,850	0.002 - 0.003	3,090	0.001 - 0.002
-	1/8	18,580	0.004 - 0.006	8,950	0.003 - 0.005	7,330	0.002 - 0.005	5,410	0.002 - 0.003	4,560	0.002 - 0.003	2,930	0.001 - 0.003
4	-	14,750	0.005 - 0.007	7,110	0.004 - 0.006	5,820	0.003 - 0.006	4,280	0.003 - 0.004	3,640	0.003 - 0.004	2,320	0.002 - 0.003
-	3/16	12,380	0.006 - 0.008	5,970	0.005 - 0.007	4,890	0.004 - 0.007	3,600	0.004 - 0.005	3,040	0.004 - 0.005	1,950	0.002 - 0.004
6	-	9,830	0.008 - 0.010	4,740	0.006 - 0.008	3,880	0.005 - 0.009	2,850	0.005 - 0.006	2,410	0.005 - 0.006	1,550	0.002 - 0.004
-	1/4	9,290	0.009 - 0.011	4,470	0.007 - 0.009	3,670	0.005 - 0.010	2,710	0.005 - 0.007	2,080	0.005 - 0.007	1,460	0.003 - 0.005
8	-	7,360	0.012 - 0.014	3,550	0.008 - 0.010	2,910	0.006 - 0.011	2,140	0.006 - 0.008	1,810	0.006 - 0.008	1,160	0.003 - 0.005
-	3/8	6,190	0.013 - 0.015	2,980	0.009 - 0.011	2,440	0.007 - 0.011	1,800	0.007 - 0.009	1,520	0.007 - 0.009	980	0.003 - 0.005
10	-	5,890	0.015 - 0.017	2,840	0.011 - 0.013	2,330	0.008 - 0.012	1,710	0.008 - 0.010	1,450	0.008 - 0.010	930	0.004 - 0.006
-	7/16	5,310	0.016 - 0.018	2,560	0.012 - 0.014	2,090	0.008 - 0.012	1,540	0.008 - 0.011	1,300	0.008 - 0.011	840	0.004 - 0.006
12	-	4,910	0.018 - 0.020	2,370	0.013 - 0.015	1,940	0.008 - 0.012	1,430	0.009 - 0.012	1,210	0.009 - 0.012	770	0.005 - 0.007
-	1/2	4,640	0.019 - 0.021	2,340	0.014 - 0.016	1,830	0.008 - 0.013	1,350	0.010 - 0.013	1,140	0.010 - 0.013	730	0.005 - 0.007
14	-	4,210	0.021 - 0.023	2,030	0.016 - 0.018	1,660	0.009 - 0.014	1,220	0.011 - 0.014	1,030	0.011 - 0.014	660	0.006 - 0.008
-	5/8	3,720	0.022 - 0.024	1,790	0.018 - 0.020	1,470	0.010 - 0.014	1,080	0.012 - 0.015	900	0.013 - 0.016	580	0.006 - 0.008
18	-	3,270	0.026 - 0.030	1,580	0.020 - 0.022	1,290	0.011 - 0.015	950	0.014 - 0.018	810	0.015 - 0.018	520	0.007 - 0.009
-	3/4	3,090	0.027 - 0.031	1,490	0.021 - 0.023	1,220	0.011 - 0.015	900	0.015 - 0.019	760	0.015 - 0.019	490	0.007 - 0.009
20	-	2,950	0.028 - 0.032	1,420	0.022 - 0.024	1,160	0.012 - 0.016	860	0.016 - 0.020	720	0.016 - 0.020	460	0.008 - 0.011





shaping your dreams

 **Safe use of cutting tools**

- Use safety cover, safety glasses and safety shoes during operation.
- Do not touch cutting edges with bare hands.
- Do not touch cutting chips with bare hands. Chips will be hot after cutting.
- Stop cutting when the tool becomes dull.
- Stop cutting operation immediately if you hear any abnormal cutting sounds.
- Do not modify tools.
- Please use appropriate tools for the operation. Check dimensions to ensure proper selection.

TEXAS
(National Headquarters)

1945 W. Walnut Hill Ln.
Irving, TX 75038, USA
Toll Free: 800-837-2223
Fax: 800-837-3334

ILLINOIS

676 East Fullerton Avenue
Glendale Heights, IL 60139, USA
Toll Free: 800-837-2223
Fax: 800-837-3334

CALIFORNIA

1921 Miraloma Ave. Suite B
Placentia, CA 92870, USA
Toll Free: 800-837-2223
Fax: 714-528-9209

OHIO

3611 Socialville Foster Rd.
Ste 102
Mason, OH 45040, USA
Phone: 513-755-3360
Fax: 513-755-3362

GEORGIA

5324 Highway 85 Ste 100
Forest Park, GA 30297, USA
Toll Free: 800-837-2223
Fax: 800-837-3334

CANADA

538 King Forest Court
Burlington, ON L7P 5C1, Canada
Toll Free: 800-263-4861
Fax: 905-632-8466

MEXICO

Avenida Central No. 186
Col. Nueva Industrial Vallejo
07700 Ciudad de Mexico, D.F.,
Mexico
Phone: (52) 55-51-19-3363
Fax: (52) 55-51-19-3370