

# CoroMill® concepts



# CoroMill® – Your first choice

Since its introduction, CoroMill has shaped the landscape of milling. With light cutting inserts, different pitch options and hardened cutter bodies, CoroMill family of tools have delivered consistent value to shops for more than 20 years. Continual refinement over the years has kept the CoroMill products at the leading edge of milling efficiency.

First choice milling cutters are available for a wide variety of application areas. To find the milling concept that best suits your needs, turn to the page for your application area and choose from the first choice milling tools.



## CoroMill® 390

The most versatile CoroMill shoulder milling cutter is perfect for mixed production.

## CoroMill® 490

It gives you the same cutting edge as CoroMill 390 but offers twice the number of cutting edges. The result: highly efficient shoulder milling.

## CoroMill® 245

A light-cutting cutter concept producing smooth surface finishes in a wide variety of materials and cutting conditions.

## CoroMill® 345

The productivity beast of the face milling world powers through the most demanding conditions.

---

**Did you know?**

The CoroMill offer includes more than 6500 cutters and 2900 different inserts. The CoroMill family of tools offers many choices to optimize your machining experience.



**CoroMill® 745**

A cross between the negative and positive face milling concepts offers a solution unique within the industry.

**CoroMill® 300**

Light-cutting and versatile round-insert concept for face and 3D milling.

**CoroMill® QD**

With a built-in solution for your most common grooving challenges, CoroMill QD cutters can transform struggling production into a smooth running operation.

**CoroMill® 331**

Adjustable for hard-to-match accuracy, CoroMill 331 is one of your core milling tools, covering a wide range of groove, side and face milling applications.

# CoroMill<sup>®</sup> 490

First choice for general and repeated shoulder milling

CoroMill 490 is a light-cutting, positive concept with four cutting edges. Precise cutter bodies and insert location along with a low-vibration machining process provide accurate shoulders without mismatch. Covers roughing to finishing.

Diameter: 20–250 mm (0.750–10.000 inches)

Max. cutting depth: 10 mm (0.394 inch)

First choice geometry and grade:

<b>P</b>	-PM	GC1130
<b>M</b>	-MM	GC1040
<b>K</b>	-KM	GC1020
<b>N</b>	-NL	H13A
<b>S</b>	-PM	S30T
<b>H</b>	-PM	GC1010



# CoroMill® 390

Versatile concept suitable for mixed production

Your "go to" cutter, the CoroMill 390 is one tool for a wide variety of component features and materials. Including a wide selection of corner radii and insert sizes for various cutting depth requirements, the reliable CoroMill 390 can mill almost any shape required.

Diameter: 9.7–200 mm (0.375–8.000 inches)

Max. cutting depth: 15.7 mm (0.618 inch)

First choice geometry and grade:

<b>P</b>	-PM	GC1130
<b>M</b>	-MM	GC1040
<b>K</b>	-KM	GC1020
<b>N</b>	-NL	H13A
<b>S</b>	-PM	S30T
<b>H</b>	-PM	GC1010



Didn't find what you were looking for?



CoroMill® 316



CoroMill® Plura



CoroMill® 690



CoroMill® 790

# CoroMill® 245

General purpose cutters with reliable performance

A simple yet sophisticated cutter, it can be used for demanding roughing jobs or when you seek that mirror finish.

Cutting edges: 4

Diameter:

Insert size 12: 32–250 mm (1.250–10.000 inch)

Insert size 18: 80–250 mm (3.000–10.000 inches)

Max. cutting depth:

Insert size 12: 6 mm (0.236 inch)

Insert size 18: 10 mm (0.394 inch)



First choice geometry and grade:

<b>P</b>	-PM	GC4330
<b>M</b>	-MM	GC1040
<b>K</b>	-KM	GC3220
<b>N</b>	-PL	H10
<b>S</b>	-MM	S30T
<b>H</b>	-PM	GC1010

# CoroMill® 345

First choice for highly productive face milling

When high productivity is your priority, these extremely robust cutters are your first and best choice due to their ability to handle a combination of large cutting depths and high feed per tooth. Shim protection offers extra security.

Cutting edges: 8

Diameter: 40–250 mm (1.500–10.000 inches)

Max. cutting depth: 6 mm (0.236 inch)



First choice geometry and grade:

<b>P</b>	-PM	GC4330
<b>M</b>	-MM	GC1040
<b>K</b>	-KM	GC3330
<b>S</b>	-MM	S30T
<b>H</b>	-PH	GC1010



# CoroMill® 745

Multi-edge cutters for best production economy

First choice geometry and grade:

<b>P</b>	-M30	GC4230
<b>K</b>	-M50	K20D

A negative cutter concept with a positive cutting action offers multi-edge, double-sided inserts with the cutting performance of a positive, one-sided concept.

Cutting edges: 14

Diameter: 63–315 mm (2.500–12.000 inches)

Max. cutting depth: 5.2 mm (0.205 inch)

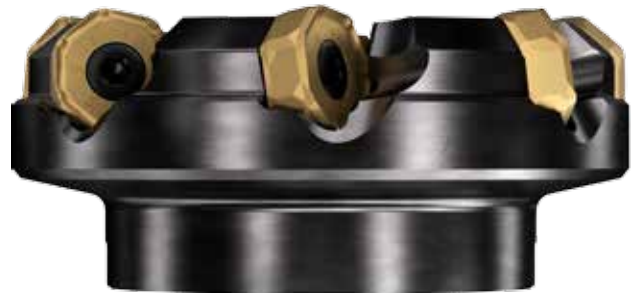

CoroMill 745 will be introduced in 2016.

Find other face milling cutters online



High-feed face milling

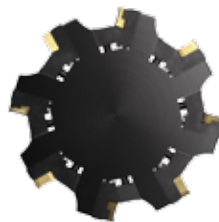

Side and face milling cutters



90-degree cutters



Round insert cutters



Heavy duty cutters

# CoroMill® 300

Round insert cutters with light-cutting action for roughing to semi-finishing

The light-cutting action of CoroMill 300 allows for smooth entries and exits and for use of extended tool set-ups. The concept is available in neutral and positive design.

First choice geometry and grade:

<b>P</b>	-PM	GC1130
<b>M</b>	-MM	GC1040
<b>K</b>	-KH	GC3330
<b>N</b>	-PL	GC1130
<b>S</b>	-PM	S40T
<b>H</b>	-PH	GC1010

Neutral design:

Diameter: 10–42 mm (0.375–1.25 inches)

IC05 to IC16

Positive design:

Diameter: 25–200 mm (1–8 inches)

IC08 to IC25.4

Max. cutting depth: IC/2

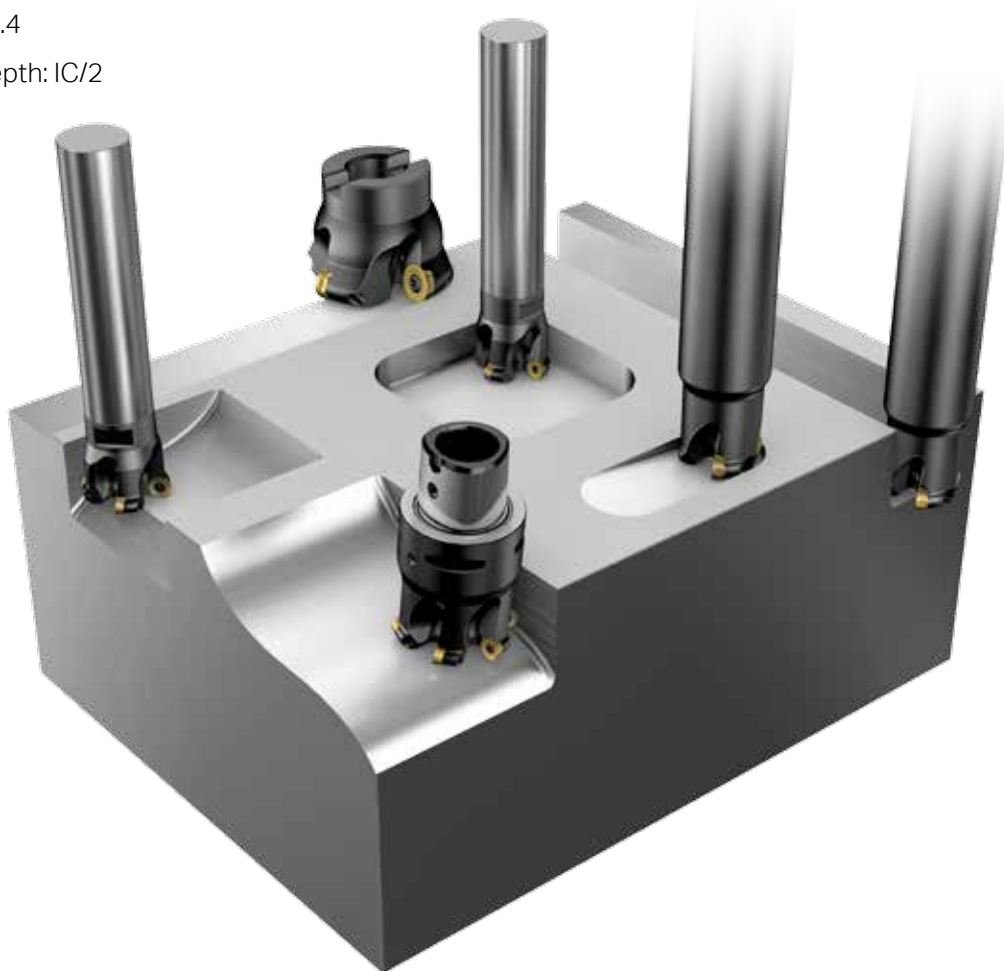



Find more profile milling tools online, including ball nose end mills, high feed cutters, and solid end mills



CoroMill® 600



CoroMill® 419



CoroMill® 216



CoroMill® 216F



CoroMill® Plura



CoroMill® 316

# CoroMill® QD

First choice for narrow, deep grooves

No other grooving cutter features the innovative internal coolant solution and damped adapters that make CoroMill QD your best choice for milling narrow grooves.

Cutting width: 2–6 mm (0.079–0.250 inch)

Max. cutting depth: 117.5 mm (4.429 inches)

Diameter: 63–315 mm (2.5–12 inches)\*

First choice geometry and grade:

<b>P</b>	-PM	GC1130
<b>M</b>	-ML	GC1040
<b>K</b>	-KM	GC1020
<b>N</b>	-NL	H13A
<b>S</b>	-SL	S30T
<b>H</b>	-SL	GC1130



\*Diameter 63 mm and 2.5 inches will be introduced in 2016.

# CoroMill® 331

## Multi-purpose side and face milling cutters

These cutters are the most productive of their kind for producing grooves and for parting off. Adjustable cassettes enable you to set the cutter with high accuracy for precise groove dimensions.

Cutting width: 6–26.5 mm (0.236–1.043)

Max. cutting depth: 114.5 mm (4.311)

Diameter: 40–315 mm (1.5–12 inch)

First choice geometry and grade:

<b>P</b>	-WL	GC1130
<b>M</b>	-ML	GC1040
<b>K</b>	-KM	GC1020
<b>N</b>	-NL	H10
<b>S</b>	-PL	S30T
<b>H</b>	-PL	GC1130

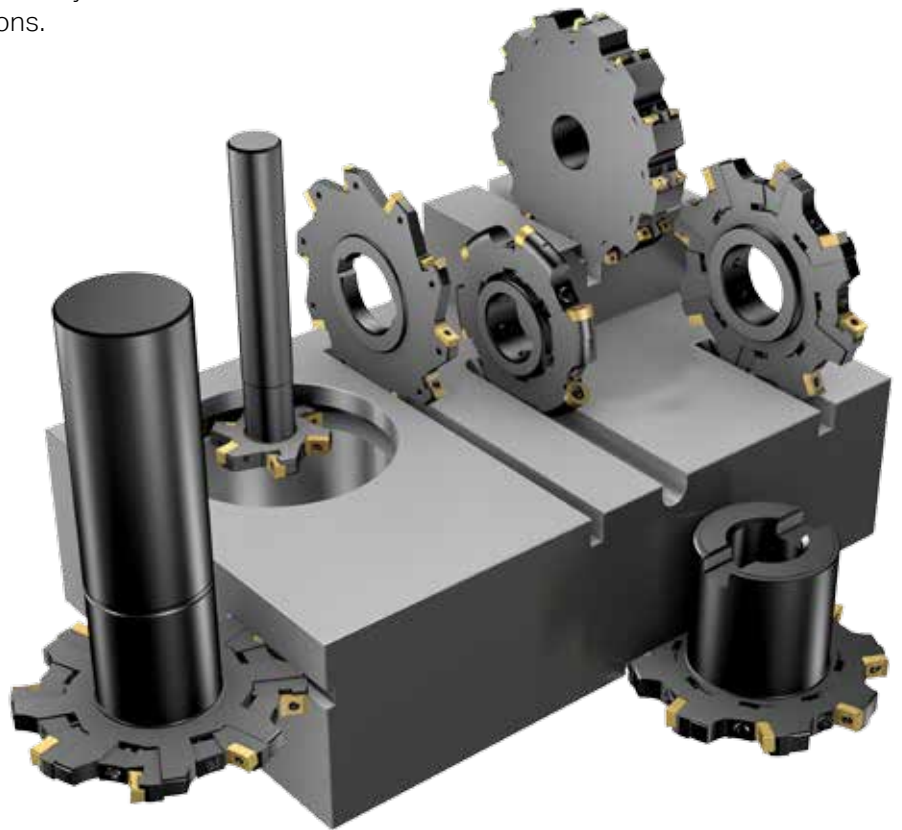

For smaller holes, diameters, and other groove widths



CoroMill® 327



CoroMill® 328



CoroMill® 329

# Order your tools



Online, printed, or digital – there are many ways to find the complete assortment and order your tools.

[www.sandvik.coromant.com](http://www.sandvik.coromant.com)

You can always find the latest assortment online.

## Publications

The digital library is available online and offline.

[www.sandvik.coromant.com/publications](http://www.sandvik.coromant.com/publications)

## Product catalogs

Use our printed catalogs and supplements.

Do you prefer a digital experience? To find your milling cutter, try CoroGuide® to get tool recommendations, find cutting data, and order online.

[www.sandvik.coromant.com/coroguide](http://www.sandvik.coromant.com/coroguide)

*SCAN TO CONNECT WITH  
DGI SUPPLY!*

